

# Fusion Simulation Project:

## Integrated Simulation & Optimization of Fusion Systems

Final Report of the FESAC ISOFS Subcommittee • December 1, 2002



$$\frac{\partial f_a}{\partial t} + \mathbf{v} \cdot \nabla f_a + \frac{q_a}{m_a} [\mathbf{E} + \mathbf{v} \times \mathbf{B}] \cdot \nabla f_a = C(f_a)$$



# **FUSION SIMULATION PROJECT**

## **Integrated Simulation & Optimization of Fusion Systems**

---

Final report of the FESAC ISOFS Subcommittee

### ***ISOFS (Integrated Simulation & Optimization of Fusion Systems) Subcommittee Members***

*Jill Dahlburg, General Atomics (Chair)*  
*James Coronos, Krell Institute, (Vice-Chair)*  
*Donald Batchelor, Oak Ridge National Laboratory*  
*Randall Bramley, Indiana University*  
*Martin Greenwald, Massachusetts Institute of Technology*  
*Stephen Jardin, Princeton Plasma Physics Laboratory*  
*Sergei Krasheninnikov, University of California - San Diego*  
*Alan Laub, University of California - Davis*  
*Jean-Noel Leboeuf, University of California - Los Angeles*  
*John Lindl, Lawrence Livermore National Laboratory*  
*William Lokke, Lawrence Livermore National Laboratory*  
*Marshall Rosenbluth, University of California - San Diego*  
*David Ross, University of Texas - Austin*  
*Dalton Schnack, Science Applications International Corporation*

## EXECUTIVE SUMMARY

---

**F**usion is potentially an inexhaustible energy source whose exploitation requires a basic understanding of high-temperature plasmas. The development of a science-based predictive capability for fusion-relevant plasmas is a challenge central to fusion energy science, in which numerical modeling has played a vital role for more than four decades. A combination of the very wide range in temporal and spatial scales, extreme anisotropy, the importance of geometric detail, and the requirement of causality that makes it impossible to parallelize over time, makes this problem one of the most challenging in computational physics. Sophisticated computational models are under development for many individual features of magnetically confined plasmas and increases in the scope and reliability of feasible simulations have been enabled by increased scientific understanding and improvements in computer technology. However, full predictive modeling of fusion plasmas will require qualitative improvements and innovations to enable cross coupling of a wider variety of physical processes and to allow solution over a larger range of space and time scales. The exponential growth of computer speed, coupled with the high cost of large-scale experimental facilities, makes an integrated fusion simulation initiative a timely and cost-effective opportunity.

Worldwide progress in laboratory fusion experiments provides the basis for a recent FESAC recommendation to proceed with a burning plasma experiment (see FESAC Review of Burning Plasma Physics Report, September 2001). Such an experiment, at the frontier of the physics of complex systems, would be a huge step in establishing the potential of magnetic fusion energy to contribute to the world's energy security. An integrated simulation capability would dramatically enhance the utilization of such a facility and lead to optimization of toroidal fusion plasmas in general. This science-based predictive capability, which was cited in the FESAC integrated planning document (IPPA, 2000), represents a significant opportunity for the DOE Office of Science to further the understanding of fusion plasmas to a level unparalleled worldwide.

***The ISOFS Subcommittee recommends that a major initiative be undertaken, referred to here as the Fusion Simulation Project (FSP).*** The purpose of the initiative is to make a significant advance within five years toward the ultimate objective of fusion simulation: to predict reliably the behavior of plasma discharges in a toroidal magnetic fusion device on all relevant time and space scales. By its very nature in enabling more comprehensive modeling, the FSP will lead to a wealth of insights not realizable previously, with new understanding in areas as diverse as wall interaction phenomena, the effects of turbulence on long time confinement, and implications of plasma self heating in advanced tokamak operating regimes. The long-term goal is in essence the capability for carrying out 'virtual experiments' of a burning magnetically confined plasma, implying predictive capability over many energy-confinement times, faithful representations of the salient physics processes of the plasma, and inclusion of the interactions with the external world. Since confidence in the ability to predict is ultimately based on code performance against experimental data, a vigorous and ongoing validation regime must also be a critical element of this project.

The characteristics of fusion plasmas make the goal extremely challenging. These characteristics include the presence of multiple time scales, ranging over fourteen orders of magnitude, and multiple spatial scales, ranging over eight orders of magnitude. The linear algebraic systems that must be solved are often ill-conditioned. The computational domains are geometrically complex, and the solutions severely anisotropic. In many cases, the physics approximations are not completely understood, and hence the simulation equations are unclear. The underlying physics is coupled with essential nonlinearities. Taken in isolation, approaches have been developed or are under investigation for each of these challenges. However, an integrated simulation for fusion plasmas will present *all* of these features simultaneously.

Success of this project will require coordinated and focused advances in *fusion physics* (to further develop the underlying models and elucidate their mathematical basis), *applied mathematics* (to further develop suitable algorithms for solving the mathematical models on the appropriate computer architecture, and to define frameworks within which these algorithms may be easily assembled and tested), and *computer science* (to provide an architecture for integrated code development and use, and to provide analysis and communication tools appropriate for remote collaboration). Strong collaborations, forged across these disciplines and among fusion scientists working in different topical areas, will be an essential element of the program. In addition, the Fusion Simulation Project will require significant improvements in computational and network infrastructure, including enhancements to shared resources as well as to local or topical computing centers. Because of the complexity of the FSP, the planning process should continue into CY2003. We recommend a staged approach: beginning with clarification of the physics issues, accompanied by efforts to address algorithmic issues and followed by clarification of architectural issues.

The necessary core expertise for the FSP is resident in several units within the DOE Office of Science. Primary among these are the ongoing fusion experimental and theoretical research and development activities within the Office of Fusion Energy Sciences, the applied mathematics development activities within the Office of Advanced Scientific Computing, the recently developed SciDAC initiative, and materials science research in the Office of Basic Energy Sciences.

To achieve its goals, the FSP is envisioned as proceeding through three five-year phases in which successively more complex and disparate phenomena will be integrated. During the first five years, the project will concentrate on specific physics integration issues that are expected to deliver significant scientific insights in their own right, but are also prototypical of the integration issues faced by the whole initiative. Each Focused Integration Initiative (FII) will concentrate on developing a predictive modeling capability for a specific programmatically important scientific problem and will begin to develop and gain experience with relevant mathematical tools, new algorithms, and computational frameworks. During the second five-year period the project will undertake larger and more comprehensive integration activities and take them to the next level of development. During the final five-year period, the focus will be on comprehensive integration. There will be links among all the physics components of the project. To provide a tradeoff between computational efficiency and physical fidelity there will be multiple levels of description of many of the physical processes.

Verification and validation are critical components of the FSP. To succeed, an integral feature of this initiative must be an intensive and continual close coupling between the simulation efforts and experiments. The phenomena in magnetic fusion devices, the equations describing them, and the interactions among the various critical phenomena are sufficiently complex that developing the most effective approximations and establishing that the models have the required accuracy can only be accomplished by continual iteration and testing against experimental data.

Funding for the FSP must be at a level adequate to accomplish the project goals. The successful NNSA Accelerated Strategic Computing Initiative (ASCI) Level 1 University Centers Program, funded at \$25M/yr, provides an appropriate example of the level of resources required. A preliminary assessment of the challenges and complexity of possible FIIs indicates that they would be comparable to that of each of the five ASCI University Level 1 Center Programs. We further estimate that four-five such FIIs will be required to cover all the critical science areas which must eventually go into the final integrated simulation code. Further refinement of the costs and timelines will be carried out as the FSP is developed. Through the course of the project, we envision that funding would be approximately equally allocated between the DOE OFES and OASCR research elements. Because this initiative rests entirely on a progressing science base, and will for successful execution attract and retain junior researchers committed to the goals of fusion energy sciences, it is paramount that FSP funding be new rather than redirected from present critical areas.

# TABLE OF CONTENTS

---

## **Executive Summary**

<b>I. Background</b> .....	5
<b>II. Overview and Recommendations</b> .....	7
a. Goals: 5,10,15 Year Overview .....	7
b. The Focused Integrated Initiative (FII) Approach .....	8
c. FSP Project Size and Scale .....	8
d. Infrastructure .....	9
e. Due Attention to Governance .....	10
f. The Need to Continue the Planning Process .....	11
<b>III. The FSP Scientific Elements</b> .....	12
a. Introduction .....	12
b. Focused Integration Initiatives .....	14
c. FII Examples .....	16
d. Insights .....	19
e. Computational Science .....	20
f. Verification and Validation .....	26
g. Infrastructure Requirements .....	29
<b>IV. The FSP Path</b> .....	33
a. Project Roadmap .....	33
b. The FSP and other Office of Science Activities .....	35
c. Roadmap Implementation: Project Governance & Management .....	36
<b>V. Summary</b> .....	39
<b>VI. Acknowledgements</b> .....	41
<b>Attachment: ISOFS Charge Letter</b> .....	42
<b>Appendix. Overview of Fusion Science for the FSP</b> .....	Vol 2

## I. BACKGROUND

In February 2002, the DOE Office of Science asked the Fusion Energy Sciences Advisory Committee (FESAC) to assist in defining a major new initiative to be sponsored jointly by the Office of Fusion Energy Sciences (OFES) and the Office of Advanced Scientific Computing Research (OASCR). The goal of this initiative, the Fusion Simulation Project (FSP), is to create a comprehensive set of theoretical fusion models, an architecture for bringing together the disparate physics models, combined with the algorithms and computational infrastructure that enable the models to work together. The required funding level for the FSP is expected to be on the order of \$100M spread over five to six years. A FESAC ISOFS (Integrated Simulation and Optimization of Fusion Systems) Subcommittee, with members from the fusion, applied mathematics and computer science communities, was constituted to generate a plan for moving forward with the FSP. The ISOFS Subcommittee membership is listed on the cover page of this document. The 2002 timeline of the ISOFS Subcommittee is shown in Fig.I.1.

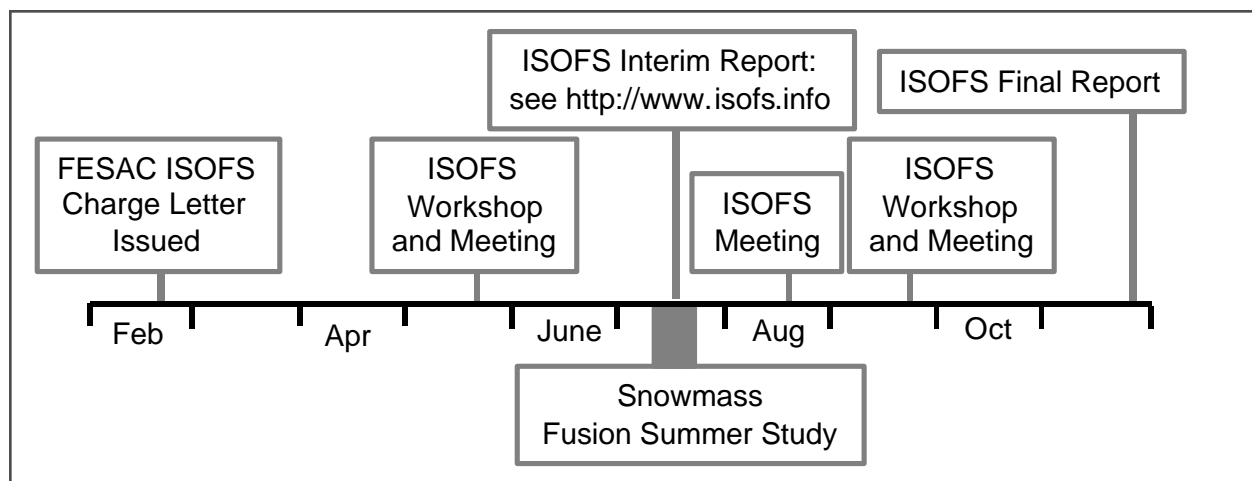

**Figure I.1.** FESAC ISOFS Subcommittee activities timeline for 2002. ISOFS Workshop presentations and discussion may be found at: <http://www.isoifs.info>.

Impetus and fundamental interest for the FSP initiative primarily comes from the goal to develop an attractive fusion energy source. The fossil fuels that underpin the United States economy cannot be relied upon to carry our nation into the 22<sup>nd</sup> Century. Oil and gas are non-renewable resources feeding a rapidly growing global energy appetite. There is also the threat of global climate change due to the burning of fossil fuels.

In the summer of 2002, fusion physicists met at the Snowmass Fusion Summer Study to plan the next stage of research towards the ultimate goal of fusion energy. The 2002 Snowmass Development Pathway Subgroup discussed the major next step plasma physics facilities in the fusion International Portfolio Approach that are required for this goal. These include advanced tokamak and non-tokamak physics facilities, a burning plasma facility(s), a Fusion Plasma Simulator (FPS), and a strong core program. In particular, the FPS is envisioned to be an integrated research tool that contains comprehensive coupled self-consistent models of all important plasma phenomena that would be used to guide experiments and be updated with ongoing experimental results. Most importantly, the

FPS would serve as an intellectual integrator of physics phenomena in advanced tokamak configurations, advanced stellarators and tokamak burning plasma experiments. It would integrate the underlying fusion plasma science with the Innovative Confinement Concepts, thereby accelerating progress. Development of a facilities class FPS capability is estimated to be a fifteen-year, \$400M activity. The FSP that is discussed in detail in this report is a first five-year stage of the ultimate FPS. The need for this kind of integrated simulation capability is recognized in the preliminary report of the FESAC Development Path Subcommittee charged with identifying the requirements for the start of operation of a fusion energy demonstration power plant in 35 years.

The workshops, meetings, and regular correspondence of the ISOFS Subcommittee resulted in the vision for the FSP that is described in this report. This final report of the ISOFS Subcommittee provides the response to the FESAC ISOFS charge letter of February 22, 2002; a copy of the letter is in the report Attachment. The report Appendix, an overview of frontier fusion science, addresses aspects of the charge and also provides a self-contained reference summary of fusion science in the context of this initiative. Responses to particular questions contained in the ISOFS charge letter are as follows:

- **What is the current status of integrated computational modeling and simulation?**  
*Appendix Section VIII with additional detail in Appendix Sections III-VII.*
- **What should be the vision for integrated simulation of toroidal confinement fusion systems?**  
*Sections IIa,b, IIIb,c, and Appendix Section IB and IX.*
- **What new theory and applied mathematics are required for simulation and optimization of fusion systems?**  
*Section IIIe, and Appendix Sections III-VII and IX.*
- **What computer science is required for simulation and optimization of fusion systems?**  
*Section IIIe.*
- **What are the computational infrastructure needs for integrated simulation of fusion systems?**  
*Sections IIId and IIIg.*
- **How should integrated simulation codes be validated, and how can they best be used to enable new scientific insights?**  
*Sections IIIId,f, and Appendix Section I, IX, and X.*

We note that this document contains a refined response to the first two charges above, building upon the initial response in the July 12, 2002 ISOFS interim report.

The FSP computational undertaking represents a significant opportunity and a significant challenge to fusion research, which has always been at the forefront of advanced scientific computing. Integrating fusion computer codes for full-system fusion simulations will require even greater research collaboration among fusion physicists, and applied mathematicians and computer scientists dedicated to putting fusion energy on the power grid. Creating the computational resources to simulate fusion will do more than substantially advance fundamental science. We will give ourselves the ability to see our energy future, and then build it.

## II. OVERVIEW AND RECOMMENDATIONS

---

The Fusion Simulation Project (FSP) described in this document is designed to provide an integrated simulation and modeling capability for magnetic fusion confinement systems. The FSP is the detailed response to findings of the FESAC Integrated Program Planning Activity (IPPA 2000), which identified the requirement for enhanced simulation for predicting the performance of externally controlled confinement systems. It is recognized that this goal can only be met through extensive and sustained collaborations between fusion scientists, and applied mathematicians and computer scientists. We note that these challenges are coming at a time of increasing opportunity between these groups, recognized in large measure by the DOE Office of Science SciDAC projects, and that the FSP will be able to further the momentum well-fostered by SciDAC. Hence,

**We recommend that a major initiative be undertaken, here referred to as the Fusion Simulation Project (FSP), to create a comprehensive set of theoretical fusion models, combined with the algorithms required to realize them and an architecture and computational infrastructure that enable them to work together.**

The purpose of the FSP is to make a significant advance toward the ultimate objective of fusion simulation: to predict in detail the behavior of any discharge in a toroidal magnetic fusion device on all important time and space scales. This is in essence the capability for carrying out 'virtual experiments' of burning, magnetically confined plasmas. This requires faithful representations of the salient physical processes individually and their interactions with the external world (sources, control systems and bounding surfaces), leading to a predictive capability over many energy-confinement times,

### ***a. GOALS: 5,10,15 YEAR OVERVIEW***

---

The goal of the FSP is to produce a comprehensive fusion simulation tool (the Fusion Plasma Simulator) by the year 2020. This tool will play an essential role in the development path for fusion energy. It will effectively serve as an *intellectual integrator* of physics phenomena in advanced tokamak configurations, advanced stellarators and tokamak burning plasma experiments. In order to achieve this overarching goal, the project will proceed through three five-year phases in which successively more complex and disparate phenomena will be integrated together. We describe this process briefly here and in more detail in Section III.

During the first five years, the project will concentrate on specific high-profile physics integration issues that are considered to be the most critical, and are also prototypical of the integration issues faced by the whole initiative. We expect to gain new scientific insights during this period. We will also develop the mathematical frameworks for the project and gain experience with computational frameworks and new algorithms.

During the second five-year period the project will undertake larger and more comprehensive integration activities and bring them to the next level of development. The mathematical framework will be expanded to include a wider range of integrated phenomena and will become standardized for the project. The project will develop a unified computational framework that aids in managing the increasing complexity, as well as integrating such aspects as advanced graphics and user interface. New algorithms will continue to be developed and refined as needed.



During the final five-year phase, the focus will be on comprehensive integration. There will be links among all the physics components of the project. To provide a tradeoff between computational efficiency and physical fidelity there will be multiple levels of description of many of the physical processes. The simulation capabilities will be extensively exercised, and comprehensive comparisons between the simulation and experiment will take place. The capability will be used to guide experiments and be updated with ongoing experimental results.

### ***b. THE FOCUSED INTEGRATED INITIATIVE (FII) APPROACH***

---

Fusion computations at varying degrees of integration have already led to significant insights pertaining to the physics mechanisms underlying the performance of plasmas confined in a range of toroidal magnetic configurations. We expect that the FSP will lead to new surprises coming from more comprehensive models and emerging from enhanced synergy between theory, experiments and modeling. This integration initiative provides a tremendous opportunity to garner new insights by addition of new physics to the plasma models and by enabling more comprehensive models through integration.

In order to realize integration from the beginning of the project, we recommend that the FSP commence with programmatic teams, subsets of the full FSP that we term Focused Integration Initiatives (FIIs). We describe the FIIs in detail in Section III**b**. The goal of each FII team is the solution of a compelling problem in fusion science physics that requires integrated simulation. The FIIs should be multi-disciplinary and multi-institutional, and by their research should integrate subsets of the full breadth of fusion fundamentals and applications of varying complexity using selected algorithms and interoperable software. The traditional modeling elements that structure our understanding of fusion plasmas include: plasma sources; turbulence; extended MHD; 1.5D (one and one-half dimensional) transport; and fusion materials. Each FII should cut across and integrate two or more of these traditional elements, to provide physics integration both spatially and temporally, with a guiding focus of a single overarching scientific question or topic that satisfies the criterion of importance to the fusion program. The community will be invited to define overarching FII themes through the proposal process.

As we envision it, each FII will focus on achieving predictive modeling capability for the particular fusion science problem it has elected to address. In order to develop a critical mass of research with adequate intellectual vibrancy, and to encourage development path risk and opportunity, the FSP should be initially comprised of 4-5 FII units. Primary to each of the FII activities must be verification of the accuracy of the new integrated model developed within the FII, and validation of the model with experimental data. Verification and validation — critical components for the FIIs — imply non-trivial supporting access to experiments, experimental data and diagnostics. We thus recommend close coupling of each FII research team with relevant experiments, and that the development of a reliable experimental predictive capability should be a substantive part of each FII.

### ***c. FSP PROJECT SIZE AND SCALE***

---

We strongly recommend that within the five-year time frame specifically considered to be the FSP, the initiative should be carried out at a scale such that certain computational goals can be achieved:

- 1) Robust computational modules are developed in each of the selected FII areas representing the state-of-the-art in physics content, numerical methods, and computational science methods, enabling efficient incorporation into the integration framework.

- 2) Approaches are developed for the fundamental problems of disparate time or space scales, and coupling of models of processes having different dimensionalities.
- 3) An initial inter-operable code capability that allows for three-dimensional geometry is available for widespread testing as a research tool.
- 4) The effectiveness of the integration approach is demonstrated by application to interpreting experimental data, and testing the validity of various physics models.

This initiative rests entirely on a progressing science base. Therefore it is paramount that FSP funding be new rather than redirected from present, critical areas. We fully support the assessment of the importance of the core fusion program that was stated in the September 2002 Burning Plasma Strategy Report: ‘The core program is ... essential to the successful and full exploitation of the burning plasma program. Predictions on the confinement, stability properties and dynamics of plasmas in the burning regime have all come from the intense experimental, modeling and theoretical efforts of the core program. The underpinnings of any burning plasma experiment therefore fundamentally rests on the foundation of knowledge that has come from the core program. Moving forward with a burning plasma experiment requires experimental scientists, engineers, and theorists and computational scientists from this core to design experiments and interpret the results.’

Further, funding for the FSP must be at a level adequate to accomplish the FSP goals. To derive an adequate funding profile that will enable a critical mass of research, we use the successful \$25M/year DOE Accelerated Strategic Computing Initiative (ASCI) Level 1 University Centers Program as an example. In that program, each strategic element or Center is receiving \$4-5M/year for each of 5-10 years. This indicates that each FSP FII team should be initiated with funding of about \$4-5M/year, and that the FSP will require approximately \$20M/year for each year of the project. Through the course of the project, funding should be approximately equally allocated from the OFES and OASCR research elements.

#### ***d. INFRASTRUCTURE***

---

The FSP will be integrated into broader fusion science and simulation activities. For example, access to experiments, experimental data and diagnostics are critical to the success of the initiative. Likewise, reliable access to suitable computing facilities will be required, including data storage and networking, and also collaborative tools. None of these items are included in the budget for the FSP as envisioned in this report. However we do stress here the need to supply a variety of computational platforms. Computational infrastructure that includes platforms of extremely high capability, and also high performance networks, will certainly be needed to achieve the goals of the FSP. The FSP will push the available envelopes of both sustained performance and long-distance researcher collaboration from the outset and as the project moves forward. The graphic below (Fig. II.1) illustrates fusion simulation performance projections in the context of past accomplishments. Storage and networking needs for the future simulation activities can be deduced from the increasing memory requirements necessary for the simulations.

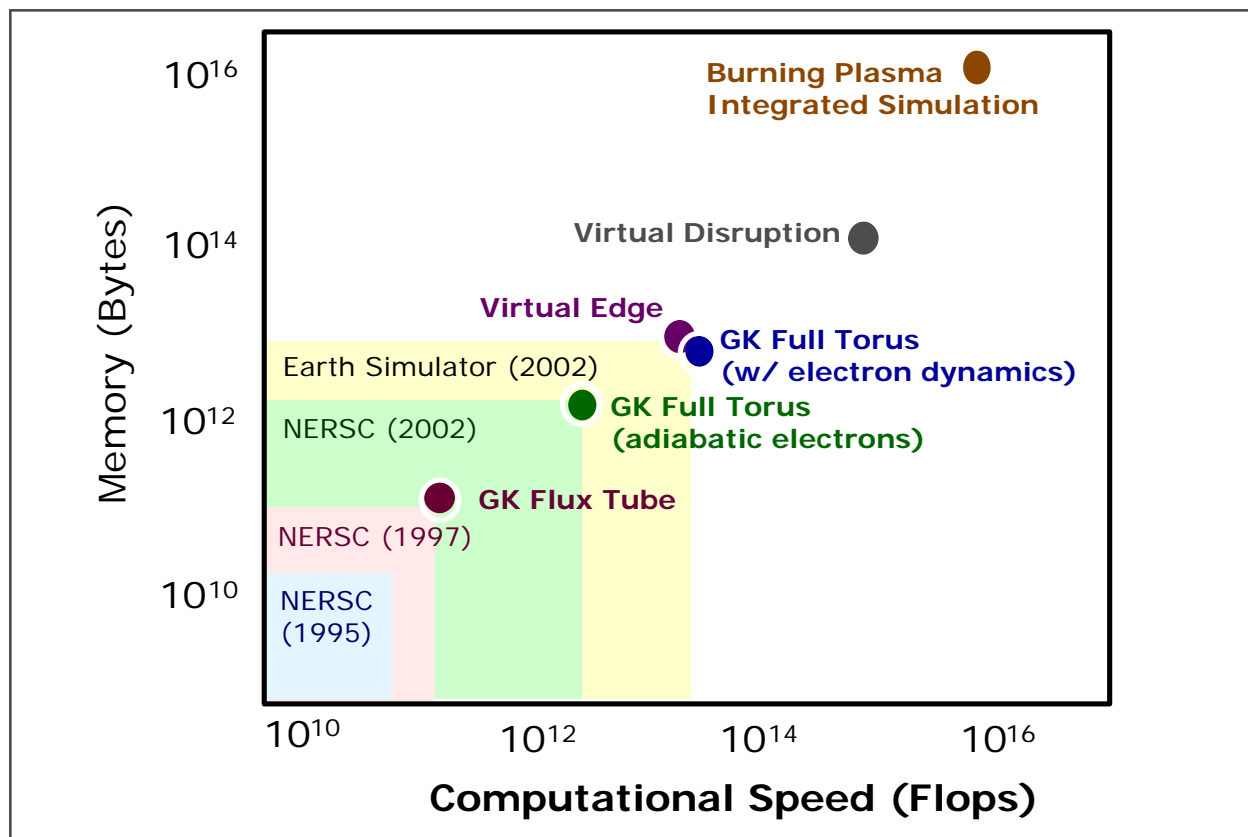

**Figure II.1.** *Computational requirements for fusion simulations.*

Further, it is essential to realize that many aspects of the project will require readily available computational cycles in real time for program development and debugging. To assure high levels of productivity by researchers, the latter are profoundly critical for success along with the ultra-scale simulation capability.

***e DUE ATTENTION TO GOVERNANCE***

To bring these disparate components together will require the dedicated skills of many accomplished physicists, applied mathematicians and computer scientists. There is no doubt that the sociology of the FSP will be a challenge. On the one hand, a strong fusion physics effort is required, involving a number of institutions and the relevant theory, simulation, and experimental communities, each of which will bring a required degree of intellectual independence. On the other hand, setting priorities and a considerable amount of central direction will be essential, for the reason that the FSP must be a coordinated, goal driven activity. Even more challenging will be effective integration of first-rate computer scientists and applied mathematicians as full partners with fusion physicists in this venture. The issue of project governance includes also the establishment of an effective cooperative arrangement between and within the two sponsor entities, OFES and OASCR, and clear delineations of working relationships with other initiatives and activities in the DOE such as the Office of Science SciDAC, the OFES fusion experiments, and OASCR computing resources. Harmonizing all of these elements, particularly in light of robust institutional competition (which is a strength of the DOE laboratory system), will require innovative, flexible management in the field and at headquarters.

Early success will require planning, leadership, and likely new management approaches. Should success be achieved, the FSP could provide a template for other large-scale cross-disciplinary computational initiatives for the future. It is our view that the next paradigm shift in problem solving ability from large scale computation may be fueled by this and other comparable major collaborative computational projects that are now ongoing (e.g., the Community Climate Systems Model [see, e.g., Kiehl, 23 May, 2002, <http://www.isofs.info>]). The sustained effort that may be required to coordinate this project to a successful outcome is well balanced by this potential. Both the investigation of the new fusion science that will be enabled, and also the possible outcomes achievable from the novel investigation of high-end computational science paradigms, well justify a substantial degree of thoughtful planning from the outset.

### ***£ THE NEED TO CONTINUE THE PLANNING PROCESS***

---

As noted above, two workshops on the FSP were held in 2002, which brought together fusion scientists, applied mathematicians and computer scientists with an interest in the FSP. The September 2002 meeting had two major goals: obtaining technical input for this report and establishing and enhancing contact among the participating communities. The level of intellectual energy and enthusiasm for the FSP activity was very high at the September meeting, and more than 100 technical researchers participated. The stage is clearly set for broad participation from all relevant sectors. While the current report addresses the relevant strategic technical issues, further thinking must be done to develop a working program plan. Because of the complexity of the FSP, this planning process is staged: *first* clarification of the physics issues; *next* clarification of the algorithmic issues; and, *finally* clarification of architectural issues. This planning process is ongoing and overlapping in time, and we expect that it will continue through the life of the FSP.

For success, we believe that the FSP planning process that has now begun should continue during 2003. Several sorts of activities should be considered:

- focused technical workshops that continue to broaden participation among fusion physicists and applied mathematicians and computer scientists;
- small working groups that begin to clarify and define the software architecture, including documenting requirements;
- venues for the clarification of needed collaborative tools; continued integration of the outputs of the above by the ISOFS Subcommittee — or whichever future organization DOE decides to enfranchise in this role — into a detailed planning document that will lead to a suitable FSP proposal call;
- as technical planning becomes more refined, activities that provide more accurate budget estimates for the duration of the FSP; and,
- attention to new and ongoing international activities in these areas with a goal of fostering collaboration where feasible.



# III. THE FSP SCIENTIFIC ELEMENTS

## a. INTRODUCTION

Central to the understanding of fusion plasmas are fusion experiments. A toroidal fusion experiment, for example the tokamak shown in Fig.III.1a, consists of an inner plasma of ionized gas confined by a configuration of magnetic fields.

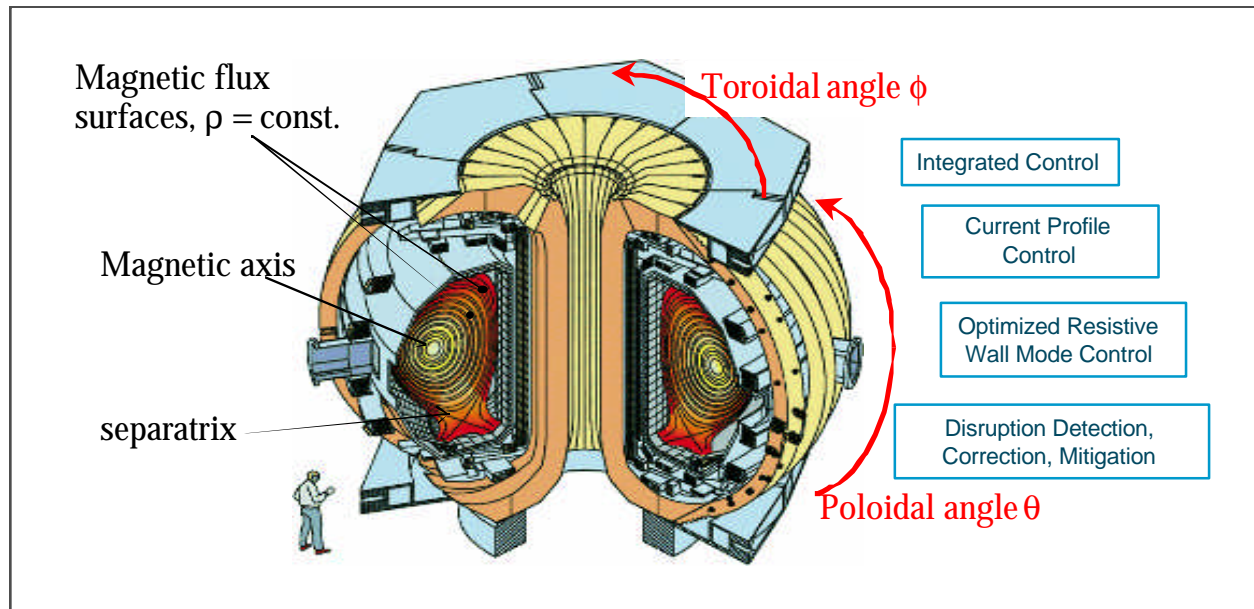

**Figure III.1a** Cutaway view of an advanced tokamak, DIII-D.

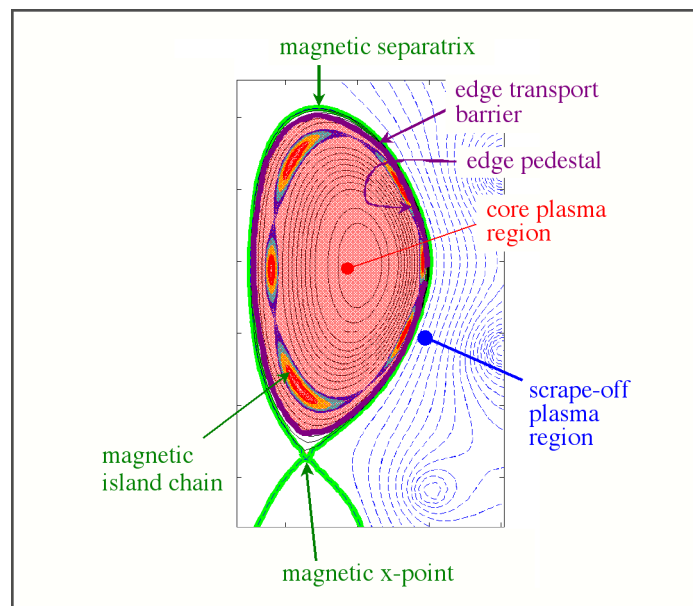

**Figure III.1b.** Key plasma and magnetic regions of a typical tokamak plasma, shown as a computed cross-section.

Plasma containment results from the formation of closed, nested magnetic flux surfaces and the tendency of the individual plasma particles, ions and electrons, to move along magnetic field lines and thus remain close to the flux surfaces. Loss of confinement or transport results from the drifting of particles across these surfaces or from the breakup of the surfaces themselves; see Fig.III.1b. The walls of the device form a vacuum chamber, which is in turn surrounded by the main magnetic coils and the various devices for diagnosing the plasma behavior and for injecting particles, energy, and momentum. Ultimately, the balance of these sources with a wide range of loss mechanisms, together with large-scale instabilities that can disrupt the plasma, determine the performance of the machine. These processes and the models used to describe them are overviewed in some detail in the Appendix to this report.

It is widely recognized that the complexity of the dynamics of fusion experimental systems is such that the development of computational models to understand their behavior is critical. Numerical modeling activities in magnetic fusion research are providing important physics understanding and routinely stretching the limits of available computational resources. However, crosscutting issues crucial to the further development of these models require a qualitative change in approach. In particular, there are two fundamental issues that have to date inhibited the integration of different fusion physics areas: the coupling of phenomena at disparate time scales and the necessity of coupling models of different spatial dimensionality.

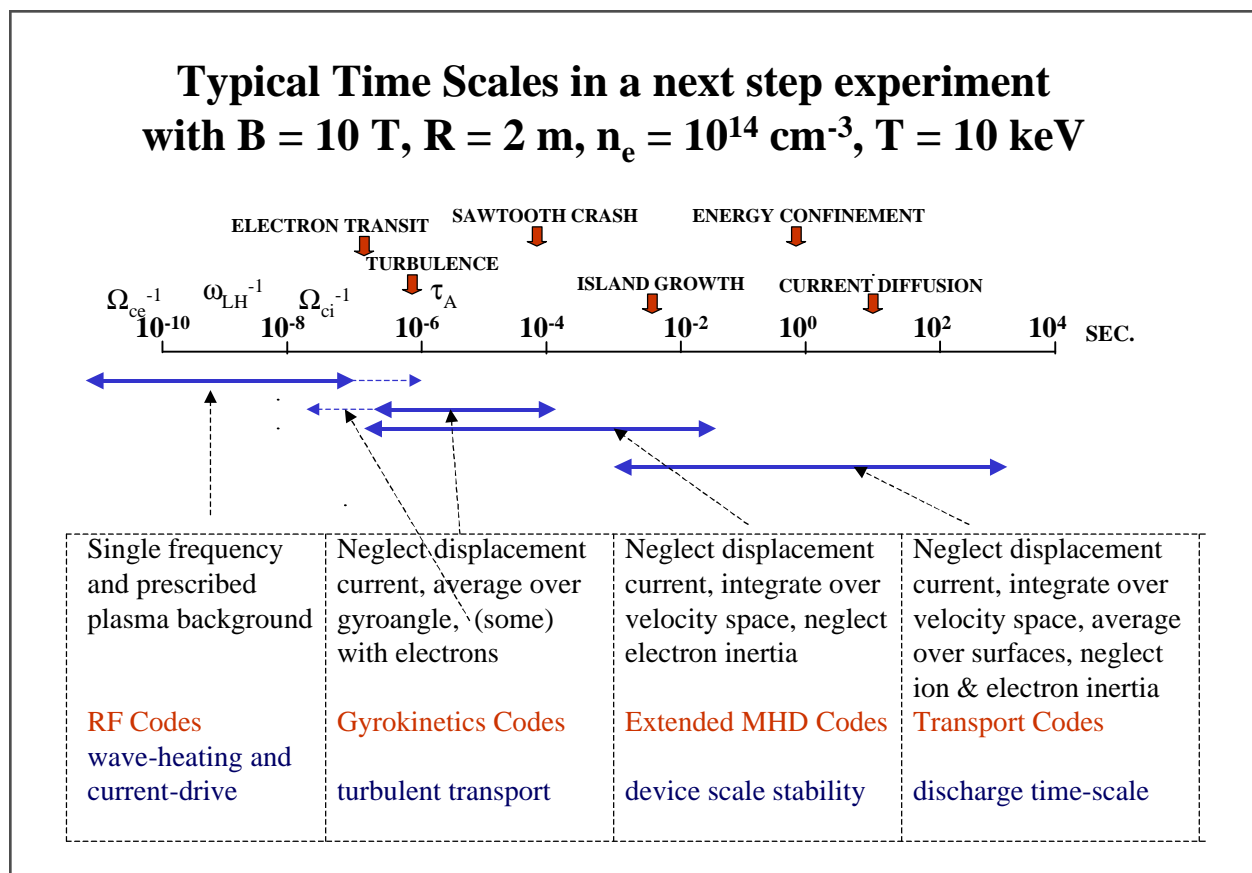

**Figure III.2.** Summary of four major fusion timescales.

A summary of the theoretically defined time scales in experimental fusion devices, and the numerical modeling presently used to investigate physics phenomena in these various regimes, is given in Fig.III.2. (See also Appendix Secs. IB and VII.) The ability to understand and predict the dynamics of high temperature fusion-relevant plasmas, in these regimes, and in the more integrated systems that will be required for further advances, is a formidable physics challenge that is central to the goals of the fusion energy sciences.

Because of the complexities, the goal of establishing a predictive simulation capability for the integrated simulation and optimization of magnetic fusion systems will require an unprecedented degree of collaboration and cooperation across many diverse areas in science and technology. For example, modern tokamaks are hot enough for the individual ions and electrons that comprise the plasma to be virtually collisionless in the direction parallel to the magnetic field, yet their ensemble can exhibit fluid-like behavior on relatively long time scales. The development of computationally tractable mathematical models that can accurately and efficiently capture simultaneously kinetic and fluid effects and describe their evolution and interaction on experimentally relevant time scales is necessary for obtaining a true predictive capability. Such an effort will require coordinated and focused advances in *fusion physics* (to further develop the underlying models and elucidate their mathematical basis), *applied mathematics* (to further develop suitable algorithms for solving the mathematical models on the appropriate computer architecture, and to define frameworks within which these algorithms may be easily assembled and tested), and *computer science* (to provide an architecture for integrated code development and use, and to provide analysis and communication tools appropriate for remote collaboration). *We emphasize that we view fusion physics, applied mathematics and computer science as fundamental to the FSP, and that healthy, focused, and sufficiently funded programs in these areas are essential to the success of the initiative.*

#### **h. FOCUSED INTEGRATION INITIATIVES**

The large scale of fusion integrated simulation ultimately called for in the 2020 Fusion Plasma Simulator is unprecedented. At this time it is impossible to define precisely the technical details by which this capability will be achieved. However, we can define a program structure that will promote a variety of technical approaches to integrated simulation while retaining the desired focus on fusion science technical results. By encouraging diverse approaches to integration we will maximize the creativity of the scientific community, and we expect that one or two of these initial approaches will eventually emerge to become adopted throughout the initiative.

First, we outline the important aspects of FSP integration. As background and as noted above, two fundamental issues are common to many fusion physics integration areas: coupling of phenomena at disparate time and spatial scales, and coupling of models of different spatial dimensionality. To solve these generic problems and achieve the integration we are seeking, strong collaboration and advances in physics, applied mathematics, and computer science will be required. Seamless disciplinary collaboration will be an essential element of the program. To this end, constitutive elements of the FSP must be both large enough to encompass a critical mass of multidisciplinary researchers and also small enough to enable team environments.

Further, an intensive and continual close coupling between the calculations and fusion-relevant experiments must be a central feature of this initiative. Phenomena in magnetic fusion devices, the equations describing them, and their mutual interactions, are all sufficiently complex that developing the most effective approximations and establishing when the models have the desired accuracy can only be accomplished by continual iteration and testing of the models with experimental data. A

continual process of testing and iteration is required to advance both modeling and the characterization of experimental results.

From these objectives flow a number of requirements that the integration design must satisfy:

- ***It must be extensible.***
  - Easy connections can be made early in the project while more difficult ones, for example those involving very disparate time-scales, can be added as techniques are developed.
  - Its architecture must permit continuous improvements and additions.
- ***It must be flexible.***
  - Only the needed physics modules required for a given study should be interconnected.
  - It must be robust to changes in physics paradigms. For example a traditional diffusive transport model will be inadequate if non-local effects turn out to be essential.
  - It must be interpretive as well as predictive. That is, it must be possible to make use of both experimental information such as profiles, and predicted information such as source rates, to interpret other needed quantities such as transport coefficients.
  - It must support choice in appropriate level of description for any of the modules in a particular study. It must allow for three dimensional (3D) effects but also be capable of lower level one dimensional (1D) and two dimensional (2D) models where appropriate.
- ***It must support collaborative research.***
  - It should interface well with experimental databases and provide appropriate tools such as synthetic diagnostics to facilitate understanding of output.
  - It must include protocols for effective communication among geographically and scientifically diverse participants.
- ***It must complement existing research.***
  - The project must provide value to the individuals involved in basic physics research, who may themselves be doing large-scale computation.
  - It must not impose significant overhead (computational or human) on the use and development of the separate physics modules. It must provide needed services so as to be of value even to the user of a single module.

***Above all, the integrated capability must technically enable fusion science***

- It must promote the development of the physics modules and their validation and verification through experimental comparison, beginning in the near term.
- It must facilitate study of mutual physics interactions presently modeled in separate codes as such interconnections become appropriate.
- It must increase significantly the depth and breadth of fusion physics compared to today's transport codes, incrementally, as better modules become available.

To achieve these goals, we believe it is necessary from the beginning to organize the project around major subsets of the whole integration problem, which pieces we term Focused Integration Initiatives (FIIs). The goal of an FII is the solution of an overarching problem in fusion physics that requires integrated simulation. The community will be invited to define the FIIs through the proposal process. As we envision it, each FII will focus on achieving a predictive modeling capability for a particular scientific problem. The FIIs will be implemented by multi-disciplinary, multi-institutional teams. The participants will be free to define a unique technical approach for each FII. Specific technical areas that should be addressed include:



**Mathematical Models:** Development of mathematical models to be included in the integrated simulation, including their underlying theoretical basis and ranges of physical validity.

**Algorithms:** Development of the appropriate algorithms for solving the equations of the mathematical models, including consistency, stability and convergence properties, the formulation and implementation of realistic boundary conditions, and performance on advanced computer architectures.

**Frameworks:** The definition and development of software tools specific to the physical models, mathematical models and algorithms that will enable rapid prototyping on a variety of architectures.

**Performance:** The development of tools to analyze and predict the performance of the models and algorithms on emerging architectures.

**Verification and Validation:** The definition and development of software to enable validation of integrated models with other models, and with experimental data.

**Data Manipulation, Storage, and Analysis:** The development of tools for the efficient storage and analysis of data produced by the integrated simulations.

**Collaboration:** The definition and development of tools that enable remote collaboration and project management.

Each FII should include approximately equal contributions from fusion physics, and from computational physics and computer science. The details of the management structure can be uniquely defined within each individual FII, although each FII will interface with other FIIs in the FSP by means of an overall coordinating body. It is likely that certain individual researchers will actively participate in and contribute to several FIIs.

Initially, the selected FIIs will likely pursue a variety of approaches to integrated simulation. Some approaches will work better than others, and it seems inevitable that in time a consensus will emerge that one or two architectures should be adopted throughout the FSP. At a decision point on this topic, it is expected that all project participants should be fully enabled to continue in the FSP.

### ***c. FII EXAMPLES***

---

In order to clarify the concept of the FIIs, we here provide some candidate examples. We emphasize that these are not to be thought of as exclusive, since the actual FIIs will be defined by the community through further planning activities as well as through the proposal and peer review processes. We consider four candidate FIIs, as shown in Fig. III.3.

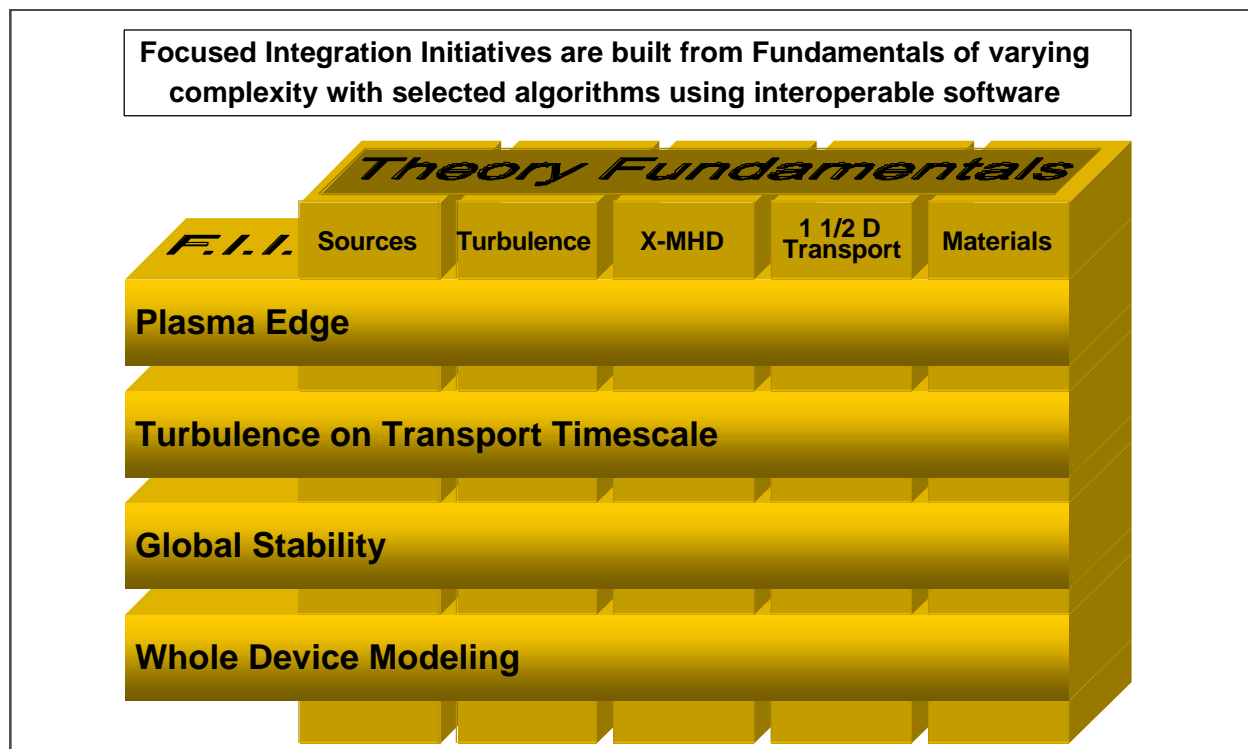

**Figure III.3:** Focused Integration Initiatives cut across all the traditional fusion disciplines.

### 1. FII Example: The Plasma Edge

**Background:** The boundary or edge-plasma of a fusion device plays a vital role in device operation. The edge plasma system extends from the top of the pedestal to a few microns inside the confinement device surface. The edge is generally considered to be the region where substantial multidimensional variations can occur in the plasma, neutral particle, and magnetic equilibrium quantities. In addition, owing to the lower plasma temperature and proximity to material surfaces, neutral gases, sputtered impurities, and atomic line-radiation can become important components. There is thus a rich variety of physics and a wealth of potential interactions that can take place in this region.

**Comparative purpose:** Four plasma edge elements are thought to be key to successful operation of an MFE fusion device: (1) predicting conditions and properties of the pedestal energy transport barrier just inside the magnetic separatrix; (2) understanding plasma/wall interactions for particle recycling and wall lifetime from high energy fluxes; (3) controlling tritium inventory including co-deposition; and (4) controlling wall impurity production and transport into the plasma. All of these elements are being encountered to some extent now in long pulse discharges in operational devices, and they will be encountered fully in a burning plasma experimental device in the ten year timeframe. A number of models of varying sophistication exist to describe these processes. Some models already provide a level of coupling, e.g., hydrogen transport, recycling neutrals, impurity sputtering, and impurity transport codes. However, many of the constituent models need improvement, and more inclusive couplings are required to self-consistently predict the edge-plasma behavior. See Fig.III.1b for a pictorial of a tokamak cross section, and refer to the Appendix for details regarding the edge plasma region.

**Overarching theme:** An early overarching issue for the edge region could be work toward a good understanding of what controls the suppression of plasma turbulence to produce a transport barrier in the pedestal region (#1 above), and its associated impact on plasma profiles and stability. The ability to predict the behavior of the edge pedestal barrier is essential for projecting the net fusion output of MFE devices. Presently, the key parameter that is believed to control the core fusion output is the plasma temperature at the top of the pedestal; this parameter is now either extrapolated from existing experiments, or assumed. Subsequent edge plasma modeling could focus on including detailed models of plasma-wall interactions, and also look to couple with core physics inside the pedestal region.

## ***2. FII Example: Turbulence on Transport Timescales***

**Background:** The nature of the problem to be considered in an FII on this topic can be summarized as follows: the ‘anomalous’ transport of mass, energy, and angular momentum in toroidal MFE devices is dominated by fluxes driven by plasma turbulence. Further, while there is a significant disparity of scales, especially timescales, this is a highly coupled system.

**Comparative purpose:** An objective of an FII in this area would be to bridge the range of temporal and spatial scales so as to compute the full system self-consistently, *as opposed to* just computing 3D fine-scale turbulence with fixed background profiles, or computing 1D transport with highly reduced theoretical or empirical models of the turbulent fluxes, as is often done at present.

**Overarching theme:** A single overarching science issue and goal is the self-consistent calculation of core temperature and density profiles from first-principles physics. An initial (easier) focus could be to determine steady-state confinement. Subsequent time evolution on the transport timescale is conceptually no more difficult but is more computationally demanding. The achievement of the steady-state goal would, as a side benefit, enable optimization studies. Important issues like simulation of both steady-state and time-dependent versions of internal transport barriers are subsets of this overall goal.

## ***3. FII Example: Global Stability***

**Background:** Global stability issues play a central role in determining the optimal operating regime of fusion devices, and in describing their time evolution. It is well known that under some operating conditions, an experimental discharge can spontaneously transform from a symmetrical stable system exhibiting good confinement into one that exhibits symmetry-breaking oscillations and poor confinement or becomes unstable and disruptively quenches.

**Comparative purpose:** At relatively low temperatures, global stability dynamics is well described as a resistive magnetofluid. Solutions of this model are complicated by a wide separation of space and time scales, and by the inherent high degree of anisotropy that occurs in a toroidally confined magnetized plasma. At the higher temperatures that occur in modern tokamaks, kinetic effects both parallel and perpendicular to the magnetic field introduce important physical processes that can affect the global magnetohydrodynamic (MHD) evolution of the plasma. Presently, mathematical and computational models that include some kinetic effects while retaining the computational tractability of the fluid model are collectively called *extended MHD*. While good progress has been made to date many of the approximations are adapted for the problems and resources at hand — and are not prescribed from first principles.

**Overarching theme:** The first-principles coupling of the transport and kinetic turbulence models to address the issues of global fusion plasma stability at all relevant temperatures and densities and inclusive of regions extending beyond the central core is a formidable problem requiring integrated modeling as envisioned by the FSP. The overarching science issue of this FII could be the predictive calculation of the onset and evolution of global symmetry-breaking events such as sawtooth oscillations, neoclassical tearing modes, disruptions, edge localized modes, and resistive wall modes, as perhaps triggered by edge plasma effects. A goal for this FII could be the development of a robust predictive capability for fusion device optimization.

#### ***4. FII Example: Whole Device Modeling***

**Background:** The distinguishing feature of a whole device modeling FII would be that from the outset it would provide a model of the entire device for the whole discharge timescale. Through its ability to allow understanding of such coupled effects, a whole, or integrated device model should connect theory to experiment, facilitate model validation, allow offline development and exploration of new operating regimes, and amplify the knowledge which can be extracted from experimental results. Such capabilities are increasingly crucial to the development of economically attractive fusion reactors, maximizing the efficient use of experiments, and accelerating design of new or optimized devices with high-confidence validated models.

**Comparative purpose:** Because of the scope of whole device modeling, existing models are at present necessarily very simple. The state-of-the-art of whole-device complete-shot modeling is represented by an array of 1D transport codes, described in the Appendix. The 1D codes have many features that would be required for a final product whole device model. They employ a formal separation of time-scales between the rapid (Alfven) time on which 2D magnetic equilibria are established, and the much slower time on which heat, particles, and angular momentum, are transported as 1D surface functions across the magnetic surfaces. They also incorporate many features of a truly integrated device model (IDM): a hierarchy of models to describe particular aspects of physics, with trade-offs between speed and accuracy; connection to experimental databases; and, predictive and interpretive modes.

**Overarching theme:** In essence, whole device modeling is a quintessentially integrated activity. It is envisioned that simple models for all relevant aspects of a whole fusion experimental device would exist in the model, and would be capable of being replaced by more complete and accurate models as they become available and/ or as warranted by the application. Problems to which a whole device modeling capability could be applied include global validation with experiment, development of new or improved experimental diagnostics, or simulation of a proposed new machine on transport timescales. It should also be possible for a whole device modeling code to serve as the 1D transport solver throughout the development of any of the new couplings in other FIIs. From this perspective, an FII initiative in the whole device modeling area would naturally overlap with other FIIs.

#### ***d. INSIGHTS***

---

In the past, computational modeling has contributed greatly to insights regarding the behavior of magnetically confined plasmas. We fully expect that the FSP will lead to new surprises coming from more comprehensive models and emerging from enhanced synergy between theory, experiments and modeling. As we start on the road to burning plasmas, some areas ripe for integration have been identified above as FIIs. These include edge physics, turbulence on transport time scales, and global stability, with contributions to the understanding of major and minor disruptions, plasma control, and effective rf heating mechanisms, among others.



By their very nature of enabling more comprehensive modeling, the FIIs will lead to insights not realizable previously. Regarding edge physics, overall transport and confinement are apparently determined by the height of the temperature pedestal at the plasma edge. It is expected that coupled and complex models of particle and heat transport, neutral and impurity fluxes, and edge gradient-induced MHD instabilities and turbulence in a single computational edge framework will pin down which of these mechanisms — either by itself or combined with another — regulates the pedestal height. Similarly, turbulence on transport time scales is a daunting physics and computational task. It is nevertheless deemed feasible at several levels, each exploiting separation of space and time scales appropriately. The result of high-confidence integrated modeling of turbulence and transport might be the discovery computationally of new favorable operating modes, with the ultimate outcome being the determination of transport from first principles. With respect to global stability, integration will facilitate extensions to MHD computations beyond the conventional ideal and resistive models, and may provide a way to control MHD activity that is as effective nonlinearly as it is linearly for realistic toroidal plasmas. Moreover, the inclusion of minority ion species with non-Maxwellian populations will enable extended MHD models to take on burning plasmas.

Perhaps the greatest innovation afforded by integrated modeling will be realized for burning plasma studies. It is well established that the grand challenge in the world fusion program is a burning plasma experiment. Such an experiment is a necessary predecessor to a practical power demo plant because, by its very nature, a burning plasma presents a new category of technical issues. With self-heating as the dominant plasma heating mechanism, new plasma processes and effects will arise. The high flux of energetic particles will impact the plasma and produce a rich source of wall interaction phenomena. Most importantly, all of these effects will be strongly coupled and must be understood and managed in an integrated fashion to insure the stability and success of the experiment. The ultimate Fusion Plasma Simulator will be targeted to model these processes and their consequences, thereby providing the essential insights to guide experimental programs, optimize machine design, provide information for fusion demo devices, and deepen our understanding of the science.

## ***e COMPUTATIONAL SCIENCE***

---

### ***1. Overview of Computational Mathematics Opportunities***

Fundamental to the mandate of a program in integrated simulation of fusion systems is that simulation with any subset of components becomes routine. Bringing interacting components to a state of self-consistency, and then performing experimental computational science by studying the behavior of the resulting integrated system as internal parameters or external forcings are varied, implies a multiplicity of nests of iteration over the components. In this environment, ‘brute force’ techniques for the individual topical analyses making up the inner loops of the integrated simulation have untenable costs in computational complexity and storage. Among the opportunities presented by the FSP are those of developing optimal discretizations and optimal solution techniques for fusion systems, and of insuring that all known techniques of potential value are propagated into the fusion context from related fields in computational physics and computational mathematics.

To appreciate the importance of optimal discretizations, namely discretizations that adapt to resolve the most physics for the memory available, or all of the required physics in the least memory, one need only consider the ‘curse’ of dimensionality. A doubling of resolution in one dimension of the six-dimensional phase-space for the Boltzmann equation, which is at the heart of much of fusion simulation, requires a 64-fold increase in the amount of memory, assuming that enhanced resolution is propagated in a uniform way throughout phase space. An optimal discretization will tune the

discretization locally to achieve a global error bound at minimum cost. This can be achieved via a gridding technique or by means of an approximation technique built on the grid, or (preferably) both. As another example, using an optimal iterative method for a sparse matrix solve as compared with a classical direct method is equivalent, in the cost of solving a Poisson problem on a cube with 100 degrees of freedom on a side, to replacing a 1 Mflop/s computer with a 100 Tflop/s computer — and much cheaper than the hardware-only solution even if some rewriting of data structures is required. Back-of-envelope scenarios for these and many other fusion-relevant numerical problems emphasize the infeasibility of stepping from departmental clusters to terascale systems without a concurrent research program in optimal algorithms for massive fusion simulations, and they underline the proverb: ‘I would rather have today’s algorithms on yesterday’s computers, than *vice versa*.’

Each of the topical areas in the FSP individually present characteristics that are extremely challenging. These include the presence of multiple time scales, ranging over fourteen orders of magnitude, and multiple spatial scales, ranging over eight orders of magnitude. In many cases, the underlying physics is often coupled with essential nonlinearities, and hence reasonable simulation equation closures are the subject of research. Once closures are decided, the solutions are severely anisotropic and the computational domains are often geometrically complex, resulting among other issues in linear algebraic systems that can be sparse and ill-conditioned.

Taken in isolation, there are approaches that have been developed for most numerical challenges as they have arisen in fusion and in other application areas. Such approaches include stiff integrators to handle problems with a wide range of time scales, adaptive meshing to optimally place resolution where it is needed most, optimal order linear solvers, physics-based preconditioners, and sensitivity analysis tools. However, an integrated simulation will present *all* of these features simultaneously, as well as additional troublesome characteristics, such as nonlocal operators, inherent physical instabilities that must be resolved numerically, and which cannot be confused with potential *numerical* instabilities, high (i.e. greater than three) dimensionality for both dependent and independent variable spaces, mixed dimensional code components, and mixed continuum-particle models, based on different but physically co-located meshes.

While the combination of problem characteristics for integrated simulation of a fusion plasma presents the applied mathematics and computational science communities with possibly their greatest challenge yet, it also presents these communities with a magnificent opportunity to explore new methodologies on problems of visibility, usefulness, and external impact. The FIIs will clearly require new modes of thinking and operation for the physicists, applied mathematicians, and computer scientists involved. For example, it is unlikely that a single speciality code can provide the base to which all others should adapt, and ultimately what has worked until now may have to be completely re-thought and redesigned. Furthermore, no transformations arranged by computer science tools alone, such as a peer-to-peer software framework to couple existing codes through their inputs and outputs, will be able to provide generality of application, ease of use, and acceptable computational performance. New algorithms, especially new discretizations and new physics-adapted multilevel preconditioners, will undoubtedly be required.

Research opportunities within an FII that will be shared by the applied mathematics, computational science and fusion science communities include:

1. **Meshing:** New methods for dealing with complex geometries via unstructured and multicomponent meshes. This includes general meshing tools for tori and topologically toroidal geometries, using both fully structured and hybrid structured-unstructured meshes in the poloidal planes. Recent developments in mesh generation, including capabilities for generating hybrid and embedded-boundary Cartesian meshes, will come into play in this research.
2. **Discretization:** Advanced discretizations of differential or integral operators using high-order or solution-specific schemes. The extreme anisotropy present in many situations of relevance to fusion science implies that PDE discretizations must be designed that respect the orders of magnitude differences in transport along vs. across magnetic flux surfaces.
3. **Local refinement techniques:** Locally refined meshing and discretization techniques that might be determined either adaptively or statically. While tokamaks have relatively fixed and well-defined geometries, the solution isosurfaces have dynamically convoluted and folding geometries.
4. **Linear, nonlinear and conservation law solver technology:** The FSP will require optimal order solvers for linear and nonlinear systems, hybrid continuum-particle solvers, fast curl-curl solvers, and stiff method-of-lines solvers (for integrating compressive Alfvén waves in the poloidal field or both compressional and shear Alfvén waves to follow slower dynamically relevant timescales more efficiently). Multilevel methods will need to be adapted to the afore-mentioned anisotropy. Also required are hyperbolic conservation law integrators, and nonlinearly consistent iterative methods for coupled physics with essential two-way finite amplitude nonlinearities.
5. **Transfer of field or particle data between representations:** An FII will require techniques for handling the coupling of code components by identifying natural representations that allow transfer of physical quantities. For example, in order for a PIC (particle-in-cell) code and a finite element code to interchange data requires more than unit conversion, and will be one area which cannot be accomplished efficiently and accurately without involving computer scientists, and will be required to translate a field representation from one discretization to another, possibly co-located in the same domain.
6. **Data management, interpretation and visualization:** Interpretation of results entails multiple numerical and computer science research issues: checks for conservation and discrete satisfaction of continuous properties, visualization, advanced post-processing, and data mining.

Following success on the direct problem of multiphysics simulation in the early years of the initiative, collaborative work with applied mathematicians would pursue sensitivity analysis, stability, design and control of experiments, parameter identification, data assimilation, experimental validation, and computational steering. These ends must be considered in the early stages of software design, however, to ensure that there is a path to the ultimate goal of scientific discovery and the computational optimization of a full burning plasma device.

Achieving FSP goals involves issues that are generic to a wide range of emerging computational science problems involving other fields of physics and engineering. Solutions can likely be leveraged across FIIs and from other similar activities such as the DOE SciDAC program. Capabilities which should be expected from the collaboration include understanding a range of algorithmic and modeling options and their tradeoffs (memory versus time, interprocess communications versus redundant computations, etc.). The simulator should be able to try a range of reasonable options from different sources easily without recoding or even recompiling. Error estimates should be

automatically provided from meshing, discretization, and iterative methods, and performance feedback provided from solvers. The collaboration should eventually help code users to spend more time pushing back the limits of physics understanding, with less time spent in coding and developing mesh generation tools and solvers. On the other hand, the code users in an FII must be willing to experiment with novel algorithms and software methodologies. These collaborations must begin early in the planning phases of an FII, with agreement on achieving the research goals of all stakeholders.

## **2. Overview of Computer Science Issues**

Any FII must provide a software methodology and framework for designing, building, maintaining, and validating the software needed for integrated simulations. A first step an FII must make is to identify the *architectures* needed, defined by the IEEE 610.2 spec as “the structure of the components, their relationships, and the principles and guidelines governing their design and evolution over time.” At least three major models are possible for fully integrated architectures starting from the current set of individual topical codes:

- 1. Peer-to-peer model:** Existing codes are adapted to communicate directly with each other, but otherwise operate as separate processes. This is the approach used in systems like University of Utah’s SciRun, Purdue’s PUNCH project, and Indiana University’s XCAT. This is a distributed software components model, and maximizes the ability for individual codes to continue to be developed independently, at the cost of large file or data transfers over the network during a simulation.
- 2. Single executable model:** Existing codes are subsumed as procedures in a single new executable. This might be done by starting with an existing code (e.g., transport or extended MHD) and then adding on other capabilities step by step. Another approach is to *refactor* existing codes by decomposing them into constituent parts and rebuild a new single code systematically designed from the ground up.
- 3. Hybrid model:** Some existing codes are integrated together into single executables, but then they interoperate as peers with other FSP modules. The codes integrated together might be topical codes that require intimate coupling because of data exchange requirements, while the separate modules have less intensive communication requirements.

Any software architecture proposed for an FII must define clearly what the functional modules and components are, indicate how interfaces between modules are defined, and provide a work flow model for how a user will ultimately build simulations from the modules. The definition of modules should follow from the chosen intellectual and mathematical integrated framework, but should also reflect two counterbalancing forces. First, physicists need to continue the full spectrum of the fundamental physics in their individual topics areas, all of which are in a rapid state of development. This implies that some upgrade path is needed that allows the scientists involved to continue running and developing their individual codes during the development of the FSP. In the limiting case, this would argue for a full peer-to-peer model. The second force is the need (driven by limited resources) to identify shared modules usable by multiple topics codes: meshing algorithms and linear and nonlinear solvers are possible candidates identified in the applied mathematics section. In the limiting case, this would argue for a fully refactored system with single executable. More generally, the components and modules in an FII architecture need to be defined at multiple



levels of granularity. At the highest level, general functional modules should be identified, which might consist of (modified) existing physics codes for transport, MHD, sources, etc. At a finer grained level, the functions/routines from which to build codes should be identified, e.g., a toolbox of solvers, meshers, discretizers, and data converters.

An FII will also have a ***data architecture***, the model of all data needed to support the research: the types of data and data objects, how they are described and defined, and their relationships. Verification and validation are critical components for the FSP framework, and supporting access to experiments, experimental data and diagnostics implies the need for well-defined data systems. Metadata (“data about data”) mechanisms will be needed; an integrated simulation may span multiple geographically distributed machines as well as multiple codes, and tracking the results of a simulation will need data systems which can locate all related outputs and allow multiple users to attach annotations to the data. Access policies and mechanisms will also need to be defined: which users get access to which data; who has write versus read permissions; and, what if any security protocols are required to protect the integrity of the data.

An architecture is implemented as a ***computational framework***. The computational framework includes how modules are linked together, the ‘run-time system’ which provides communications and control between modules, and lifecycle control (starting, stopping, killing parts of the computation). A computational framework might take the form of a ***problem-solving environment*** (PSE), which is the full set of utilities and tools needed to set and solve a range of problems from a particular domain. A PSE often includes a graphical user interface, a way of describing problems in the language natural to the problem domain, and specialized post-run analyses that hide complexity from the user.

### ***3. Computer systems issues an FII must address***

The central goal for an FII is the complete integrated simulation of an overarching fusion physics problem, with the eventual goals of predictive simulation of a burning plasma and parameter optimization that can lead to more efficient magnetic confinement devices. Accomplishing these goals will require addressing several important but straightforward computer science issues. From a software engineering point of view, an excellent proposal will include the following items.

***Requirements analysis:*** A process is needed to identify the components and capabilities necessary to accomplish both the short and long term goals. Both envisioned scenarios and more formal ‘use cases’ could be helpful in deriving the requirements. A project like the Fusion Plasma Simulator will have evolving requirements over its lifespan, and the process used for changing requirements needs to be specified.

Sample requirements could include:

- 1. Computer languages:** Will the computational framework be required to support multiple computer languages, or will all components be required to have an interface in a single language?
- 2. Code ownership:** Will the components be “owned” by their creators, or be community-owned, or be required to be open-source? Will commercial software be used, and if so what licensing will be necessary to assure long-term viability of the proposed FII?
- 3. Platform dependence:** Will components be required to run on particular operating systems and hardware platforms? How are those chosen and what support will be needed for porting and testing between platforms if more than one is chosen?

- 4. Performance requirements:** An integrated simulation system will not run faster than the slowest of its components. What are the performance requirements, and how will they be expressed?

**Survey of existing systems:** Many frameworks, systems, and architectures are currently under development and being used for high-performance scientific computing. Examples include CACTUS for computational astrophysics, the DOE's Common Component Architecture, Argonne's PETSc libraries of linear and nonlinear solvers, the National Transport Code Consortium, the University of Utah's SciRun framework, the Community Climate Modeling System. Identification of what can be utilized from these and other similar projects, ranging from design to codes, and what if any deficiencies they have for the FSP, will enable leveraging these existing code bases.

**Basic software maintenance:** An FII will likely span multiple laboratories, developers, and geographically distributed sites. The code development as well as the final product will be shared, so formal systems for software development and maintenance are required. Some version control system like RCS, CVS, BitKeeper, or SCCS can help in coordinating distributed development, and keeping archival versions of previous releases. Some formal bug tracking tools should be used since the software is likely to be under rapid parallel development by separated code teams. A framework for unit and regression testing will allow automated testing and notification of stakeholders in the FSP of potential problems from updates. Software maintenance is a critical infrastructure for successful development and deployment.

**Development path:** A migration plan must be provided that indicates how to move from the current standalone codes in different topical areas to an integrated physics framework. This path needs to reflect the requirements of participating code users to continue producing research with their codes during the development of an FII framework. Software engineering research has shown that there is typically a 50% higher cost to develop components to the high quality standards needed for re-use and sharing; however, once a core of usable and useful components is available they can raise expectations and draw in other developers.

**Flexibility and extensibility:** Each FII should have a plan for tracking and using software utilities and components developed by other FIIs. Eventual interoperability and shorter-term shared module development need to be identified and exploited whenever possible. The problem domain that the FSP framework handles must be explicitly stated.

**Data models:** A description of the data that needs to be shared or communicated between components of the architecture at runtime must be provided. How is the data described programmatically (e.g., using HDF5 descriptors or XML schema), and how is the data model extended to unforeseen future data interactions? In addition to static information about data objects and how they are defined, each FII needs to provide estimates of how often interacting components need to exchange data, the sizes of the data objects in those interchanges, and what if any data mediators (for interpolation, unit conversion, coordinate transformation, etc.) are required. Related to this is a networking requirements analysis, describing what must be transferred over local or wide area networks, the network capability of the participating sites, and what parts of an integrated simulation will require special high-speed connections, quality of service guarantees, or special security protocols.

While the items above are basic requirements for any FII proposal, additional desiderata might include:

- The ability to work hierarchically with the components of the architecture: an expert in extended MHD should be supported by the framework in assembling a MHD solver with variant capabilities or to explore new methods. At the same time, an expert in RF sources should be able to use a framework-provided ‘default’ MHD component without becoming an MHD expert.
- Rapid prototyping capabilities, or the ability to run selected components in a lower-fidelity mode for quick tests and proof of concept simulations: this also refers to the ability to quickly compose, compile, and launch ‘what-if’ scenarios using the framework.
- Collaboration support, such as human interactions via videoconferencing, shared code development and distribution tools, and a shared testbed of hardware and software used by everyone on the same FII, or across multiple FIIs: this underlies the concept of virtual FII centers of research.
- Data analysis tools, that can be used across physics regimes, mesh and discretization techniques (PIC, AMR, finite elements), and disparate codes: this includes visualization but may also include statistical summaries, consistency checkers, etc.

These additional considerations are more generally characteristic features of problem-solving environments.

While an overall governance structure will be mandated for all of the FIIs within the FSP, as described elsewhere in this report, a successful proposal should also be required to address some local governance issues related to the computational science infrastructure proposed. Software version control, bug tracking, and code configuration and maintenance methodologies are of little help unless all the stakeholders use the proposed system. Users will be required to follow some standards, but if too onerous they will be ignored. Particularly in situations where stakeholders are geographically dispersed, a priori agreements need to be worked out on timely responses to issues reported, and the level of support that individual component suppliers are expected to provide.

## ***£ VERIFICATION AND VALIDATION REQUIREMENTS***

Since the goal of the FSP is to build models capable of accurate prediction, it must be in a position to assess the reliability or accuracy of these models at all phases throughout the project. Assessment of predictive models has been divided into two distinct activities: ***verification***, which assesses the degree to which a code correctly implements the chosen physical model and ***validation***, which assesses the degree to which a code describes the real world. The former is essentially a mathematical problem (in a broad sense) while the latter is essentially a physical problem. ***Overall, the goal of verification and validation is an assessment of the extent to which a simulation represents true system behavior sufficiently to be useful.***

As documented in IPPA 2002 and the 2002 Snowmass Fusion Summer Study documents, predictive capability based on scientific understanding is a key goal of the fusion energy sciences program. The accuracy of our predictions, when mapped to the fusion energy mission, has significant economic consequences. Reactor scale devices are expensive, and uncertainty in the underlying science requires extra margin in their design. Formal verification and validation regimes have been defined and applied to ‘high consequence’ applications like national defense, environmental protection and nuclear power and in some cases linked to the regulatory schemes for the systems in question. While

we can learn much from work of this rigor, we need to introduce a validation and verification governance regime appropriate to the goals and scope of the FSP. Cost/benefit/risk tradeoffs will need to be made as the project management allocates manpower and other resources. It is also important to recognize that verification and validation is an iterative process carried out over the life of a project, not a one-time test.

### **1. Verification**

The verification process attempts to identify and quantify errors in the computational model and its solution. As such it must logically precede validation. Sources of error include algorithms, numerics, spatial or temporal gridding, coding errors, language or compiler bugs, convergence difficulties and so forth.

The most powerful tool for verification of an individual model is comparison with analytic solutions to the same conceptual (physical) model. This is not always easy since analytic solutions are often only possible in very simple regimes. Comparison between codes is also useful, pointing out the importance of maintaining diversity and breadth in the code library. Codes that use radically different approaches to their solutions provide the most thorough tests. Internal checks for consistency and convergence are, of course also essential, by changing gridding, timesteps, and sometimes even solution algorithms.

For an integrated suite of physics models, verification can present more of a challenge, since there is typically no analytic solution available and there may not be other existing coupled computational models. But there are various options, depending on the type of coupling. First, when available, is comparison with other coupled computational models (either completely independent code efforts, or multiple approaches to coupling implemented within a given code). Also, in some cases a coupled approach can be compared with a 'brute-force' direct simulation of the same physics. For example, a coupling of turbulence and transport can be benchmarked against a background-evolving turbulence code for test problems where the timescales are not too disparate, or a coupling of one-dimensional core transport and 2- or 3D edge transport can be compared with an edge transport calculation that extends all the way into the core. Or, a code that integrates different kinds of physics into a single set of equations can be operated in limits where one kind of physics is expected to dominate and then compare with an existing code that calculates the dominant physics.

In all of these approaches it is helpful to operate within a computational problem solving environment that facilitates side-by-side execution and comparison of multiple computational approaches.

### **2. Validation**

A successful validation regime must begin with planning. An FII must clearly define the goals of the predictive code - what is driving the need for the calculation? Since validation is not a mathematical process, it is only really meaningful in the context of a well-defined application, such as an overarching area of assessment as defined by an FII. The validation regime attempts to assess quantitatively the ability of a code to predict and to define the boundary between acceptable and unacceptable extrapolations; this defines applications for which the code can be trusted. Next, the FII participants must identify the critical issues, design real and numerical experiments, specify metrics and define assessment criteria. Planning is the place where resources are balanced against other elements of the project. Since validation necessarily involves experimental groups who are

outside the simulation project and funded independently, contacts should begin at the onset of FII planning. Critical diagnostics may need to be developed and deployed as part of the overall program, and synthetic diagnostics developed and employed in the simulations. New diagnostic techniques can also be discovered by this process.

The principal validation activity is the design, execution, and analysis of dedicated experiments, both real and numerical. Comparison with historical data from existing archives is useful but almost certainly not sufficient. The crucial comparisons are those designed to test important features of the model and evaluate critically and quantitatively. The experiments must be designed to collect essential data for comparison, particularly initial and boundary conditions needed by the code. Experiments should challenge the codes in fundamental ways and explicitly test the model's assumptions. A hierarchy of measurements and comparisons of increasing difficulty should be established, for example progressing from global to local variables and from steady state to transient conditions.

Experimental design needs to be collaborative between the code project and experimental team. Typically it will require use of simulation as part of that design. In this manner the experiments can be optimally useful and can stress critical parameters and measurements. Use of the codes at this stage help build the collaborative environment, tools and working methods that will be necessary during the measurement and analysis phases. The groups must form a team for the purposes of validation. The team should not have the goal of proving the code is correct, but dispassionately evaluating its status. At the same time, the experimental team must be frank and forthcoming about limitations and errors in the experimental data. The availability and quality of data is a critical need for the validation program and raises the very large issues of error analysis and experimental data validation. Typically evaluation of random errors is straightforward while estimation of systematic errors is not. Often the latter is no more than a 'seat of pants' estimate. Although experiments must be developed collaboratively, independence should be maintained in data collection and analysis.

Each FII, and ultimately the FSP as a whole, must define metrics by which the comparison between the code and experiments are to be evaluated. The metrics need to take account of all sources of error: experimental, both random and systematic; and, assumptions and approximations in the model as well as convergence or numerical errors. Using these metrics, the FII team then must make an assessment of its status. The assessment is essentially a statement of confidence in the code in a particular area and confidence in the ability of the code to extrapolate or predict. (The importance of the latter suggests greater weight be given to predictive tests rather than postdictive comparisons.) Standard statistical analyses for hypothesis testing may be appropriate for this task.

Finally, the process and results need to be well documented. This should include a description of the experiment, the full set of experimental data and metadata, the assumptions, parameters, inputs and outputs from the code, a description of the analysis procedures and error estimates, along with the metrics and assessment. This should be kept as part of the documentation of the FII. Specific validation requirements in topical areas are given in the Appendix.

## ***g INFRASTRUCTURE REQUIREMENTS***

---

We have discussed the FII concepts, the architecture issues, and verification and validation of the FII developing capabilities. All of this hinges on resources available to produce results, i.e., the computational capabilities available to the FSP. This section highlights some of the salient features of this fundamental project need that is external to the resources of the FSP.

### ***1. Computational Resources***

To realize the benefits of the developing simulation capability will require three rather distinct types of computing resources:

1. interactive or rapid turnaround resources for short to moderate times, at all ranges of relevant memory (e.g., including largest numbers of processors for short times) for purposes of code development and debugging, testing of physics formulations, code components, and numerical methods;
2. substantial computer resources for very long periods of time for production runs and parameter surveys. In this case a figure of merit is the number of usable flops available over the course of a year, not the maximum achievable flops, and need not necessarily be on the largest, fastest machines; and,
3. the largest memory, fastest processor machines to allow exploration of extremely challenging physics regimes having high resolution requirements, large Reynolds number, high dimensionality and the like, to push a verified, validated computational capability into a regime that is wholly new.

Each of the fundamental areas of fusion theory are now pushing the limits of computation of the types listed as 2) and 3) above. For example, the key challenge in performing Extended MHD computations relevant to the hot plasmas of modern fusion experiments is to increase the dimensionless parameter characterizing inverse plasma collisionality, the Lundquist number,  $S$ . Present Extended MHD calculations have achieved 18 Gflop/sec (GF) on 384 processors of an IBM SP3. This performance limits both the accessible Lundquist number ( $\sim 10^7$ ) and the problem time ( $\sim 1$  msec). These values are several orders of magnitude less than are required to accurately simulate present fusion experiments. It is estimated that a 1000-fold increase to 20 Tflop/sec (TF) sustained performance could allow values of  $S$  approaching  $10^9$  and the problem time to approach a tenth of a second or more, enabling validation of the mathematical models and comparison with present experiments. Further extensions into the 100s of TF regime would likely be needed to treat some key problems for burning plasma devices.

At the present time roughly  $10^{-3}$  s of a turbulent discharge can be modeled at minimal spatial grid resolution with 120 hours on 128 processors on the NERSC IBM SP (115 MF sustained performance per processor  $\rightarrow$  1.5 TF hours). This time needs to be increased by a factor of 10-100 to address transport time scales. Furthermore additional physics associated with kinetic electrons (which necessitates an increase in computing resources  $\sim 50$  to 100) and electromagnetic coupling must be included in the models in order to allow a quantitative understanding. Codes in the SciDAC Plasma Microturbulence Project have recently added this physics capability, but presently there are insufficient computer resources to carry out the scientific studies. It is estimated that  $10^3$  to  $10^4$  TF hours are required to include kinetic electron dynamics for transport time scales.



A gyrokinetic edge code simulation would require a capability in the 20 TF (sustained performance) range to simulate up to nominal background relaxation timescales. Full-shot simulation, or simulations requiring coupling to the largest spatial scales, e.g. for edge-localized modes, would require at least an additional order of magnitude.

Codes which solve the full, hot plasma wave equation in 2D and 3D, to all orders in Larmor radius divided by scale length and including all cyclotron harmonics have been developed under the SciDAC program to study wave heating, current drive and plasma flow drive. These codes scale well and have achieved efficiencies ~40% relative to theoretical maximum using 1600 processors on the NERSC Seaborg machine. High resolution solutions in 2D to study fast wave mode conversion typically require a few TF hours per toroidal mode calculated. A full antenna spectrum of ~50 toroidal modes then would require ~100 TF hours. A low-resolution solution in 3D for fast wave propagation required ~ 30 TF hours.

As we seek to integrate the disparate plasma models, it is realistic to expect that the level of fundamental physics detail that can be incorporated will be dictated by the available computer resources. Two to three orders of magnitude increase in effective computing may be required to achieve the program goals. This increase can come from several sources: more, and more problem efficient, computer hardware; improved physics analysis resulting in more accurate reduced models; and, improved algorithmic and mathematical methods.

## ***2. Network and Storage***

Requirements for network connectivity and mass storage are driven by the vast quantities of data that will be produced by the proposed simulations and by the geographical distribution of participants and computational resources. Precise quantitative predictions are difficult since the frequency with which simulations will be performed, the amount of data generated, the amount of that data that will need to be stored or transferred, how quickly after a simulation data will be needed and how many sites/people will use the data are all uncertain at this point. In part, these depend on the FIIs chosen, and in part on other issues such as researcher proximity. Still, even under the most prosaic imagined situations, rough estimates yield numbers which are large enough to warrant serious attention. Over the next five years, three dimensional, non-linear MHD and turbulence codes may be generating on the order 1 PByte per simulation. We may further hypothesize that, integrated over the entire project, it would be desirable for major simulations, each representing a full, integrated experimental “shot” to be completed on the order of once a week. (This also is practically possible. Consider: 1000x1000x100 spatial zones, 10 variables per zone,  $10^6$  time steps, and assuming 100 floating-point operations per variable per space-time point, such a calculation would take no more than a few percent of 50 TFlops machine to complete in a week.) By this estimate, aggregate rates in the 10’s of PByte per year should be planned for. It is not sufficient to simply archive this data; scientific progress will be linked to our ability make effective use of it.

Meeting these challenges will require a highly capable network, massive storage infrastructures, along with advanced middleware and network services to “glue” them together. All of these elements are required resources for access by the FIIs. Simply moving the estimated simulation data once would require dedicated links at several Gbps. Distributing the data to multiple sites over a wide area network, while technically feasible in the project’s time frame, is probably not an economically reasonable approach. Instead, the researchers should plan on moving only that part of the data necessary for visualization or post-run analysis. Assuming a data set for local analysis or visualization is 10-20 GBytes (a reasonable guess for the RAM capacity of a workstation in the next five years), and that 10 or 20 seconds is a reasonable waiting time, one calculates a requirement for burst transfer rates

up to 1 Gbps. Alternately, post-processing or visualization engines could be co-located with the data store and the results streamed to end users. An HDTV stream requires about 50 Mbps, a large display wall, fed with uncompressed data could use 1 Gbps. Thus the network requirement may be estimated conservatively as one that supports a large number of users (perhaps 50-60) located at most of U.S. fusion sites each transferring bursts of 1 Gbps at duty cycles of a few percent.

Data storage in a reliable and robust repository (or repositories) is another formidable challenge. In analogy with experimental data, results generated for major simulations will be of archival quality. The estimates shown above, suggest that data will accumulate at 10's of PBytes per year. As with the network requirements, these rates are not technically insurmountable but do require significant thought as every decision concerning archives of this magnitude will have a serious impact on the ability of the team to carry out the scientific program and on the economics of the project. Architectural decisions include where to store the data, whether to centralize or distribute the archive, whether to support data replication at remote sites, how to integrate post-simulation analysis, how to integrate with experimental archives, and how to guarantee data integrity and consistency. With such a large quantity of data, automated mechanisms for constructing data digests, databases or summaries and new and improved ways to efficiently mine the repositories to extract knowledge will need to be developed.

With distributed resources for software development, computing, storage, analysis and visualization, the project will require advanced network middleware that supports distributed computing and collaboration. At the same time the apparently conflicting requirements for transparency and security in a widely distributed environment point up the need for efficient and effective network services. Central management of Public Key Infrastructure (PKI) or equivalent technologies using 'best practices' and providing around the clock support is essential. It is equally essential that the user authentication framework adopted is such that common policy can be negotiated among the collaborating sites. Mutually agreed upon tools and protocols for resource authorization is also important. For such a large user base and with the need for close collaboration with experimental groups on validation tasks, global directory and naming services may be a key technology and may help to anchor the wealth of distributed metadata. A hierarchical infrastructure with well-managed 'roots' can provide the necessary glue for many collaborative activities. A global name service could also solve the longstanding problem for our field of variable name translation between codes or experiments. Since users, including partners at universities, private companies and international sites are interested only in end-to-end performance, real-time network performance monitoring and problem resolution tools which work across administrative domains will be essential. Finally, a host of collaboration services including teleconferencing, distributed applications and remote visualization will be required.

### ***3. Summary of infrastructure requirements***

High-end infrastructure requirements are summarized in the table below. In addition, the project will need local infrastructure consisting of medium scale computing clusters for development, testing, and post-processing; powerful desktop and visualization systems; medium scale storage systems and well provisioned local area networks.

	<b>Now</b>	<b>SOON</b> (1-3 years)	<b>LATER</b> (> 3 years)
<b>Computers</b>	~4Tflop/s ~2TByte memory	10's Tflop/s TBytes memory	100's Tflop/s 10's TByte memory
<b>Storage Networks</b>	~50TByte/year 0.1 Gbps to desktop 0.62 Gbps backbone	~1 PByte/year 1 Gbps to the desktop 10 Gbps backbone	10's PByte/year >1 Gbps to the desktop 100 Gbps backbone

Table III.1. *High-end fusion simulation infrastructure requirements.*

## IV. THE FSP PATH

### a. PROJECT ROADMAP

The goals of the FSP both near, five-years, and longer term, ten-years and fifteen-years, are ambitious. To meet them careful but flexible planning coupled with a well-designed program governance and program management structure is required. To put governance and management requirements in context, Fig.IV.1 below provides a summary roadmap of the FSP goals.

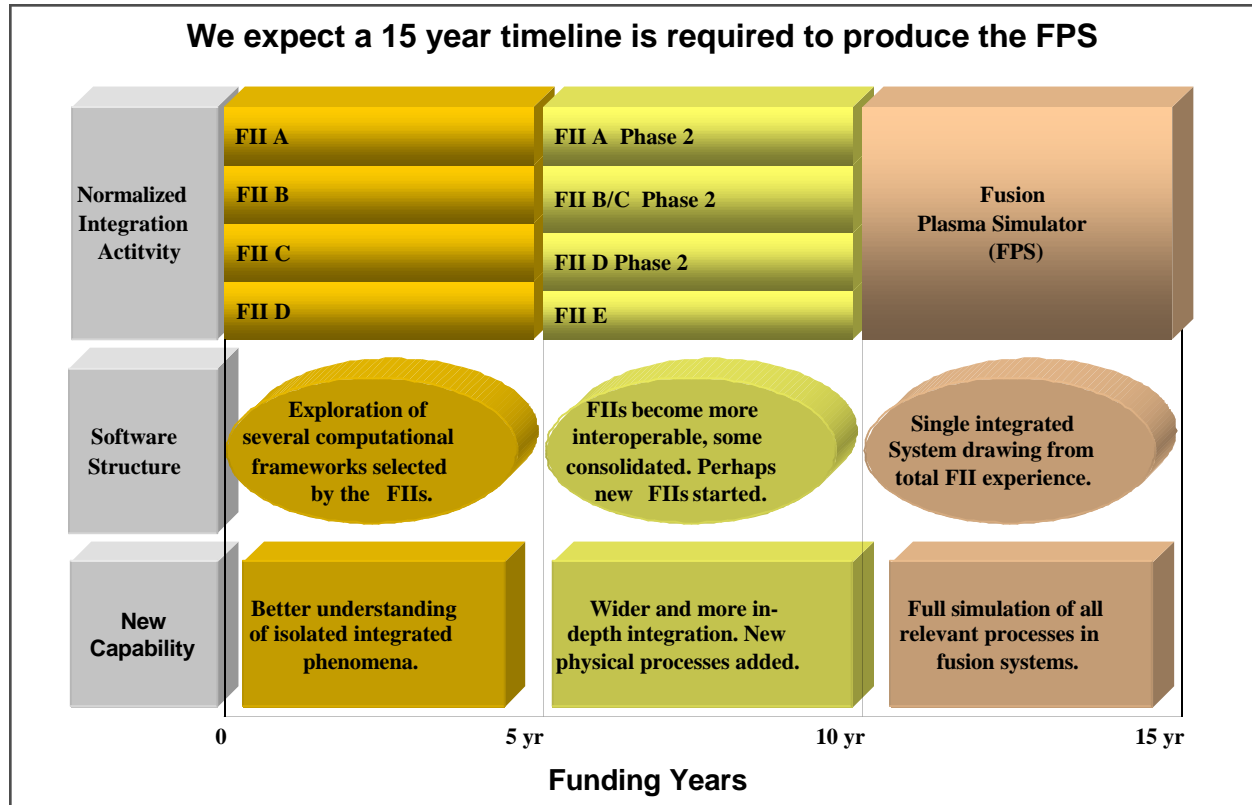

**Figure IV.1:** Fifteen-year roadmap for the Fusion Simulation Project

The plan shows a fifteen year timeline, with significant value and specific milestones at the end of five and ten years. As noted in the 2002 Snowmass Fusion Summer Study, the full extent of the Fusion Plasma Simulator project is expected to require funding on the order of \$0.4B throughout the fifteen year period.

The three major phases of the project are described in the following paragraphs.

#### **First five years**

During the first five years, we will initiate several Focused Integration Initiatives (FIIs) as described in Section III. These will be concentrated on specific high-profile physics integration issues that are considered to be the most critical, and are also prototypical of the integration issues faced by the whole initiative. Each FII will be quasi-independent of the others, but there will be efforts made at

coordination between initiatives, looking towards future integrations. We expect at the end of the five-year period to have substantial new capability in each of the FIIs and to gain new scientific insights during this time frame.

Each of the FIIs will be expected to develop a computational framework best fitted to its task. Since there is not universal agreement on the best way to solve many of these integration problems, the computational framework also needs to allow rapid prototyping of different solution techniques over some range of hardware architectures.

New computational algorithms will be developed to treat the unique mathematical problems present in fusion science. For example, many of these arise from the presence of the strong magnetic field, which adds an extreme anisotropy to the plasma and results in temporal and spatial anisotropy of particle motion. Also, the mathematical equations describing plasma waves are higher order parallel to the field than across it. These physical effects lead to sparse matrices with peculiar properties, to the need for very specialized gridding techniques, and to the need to deal with “stiff” equations on disparate time scales.

### **5-10 years**

During the second five-year period, we expect several things will occur. One is that we will begin to combine select FIIs into larger and more comprehensive integration activities. Another is that we will introduce new FIIs as required. A third is that we will take select FIIs to the next level of development.

During this period, there will also be a comparative reassessment of the issue of computational frameworks. We expect the frameworks to grow in maturity, integrating such things as advanced graphics and user interfaces, and also that some down-selection and solidification will occur. A unified system for effectively managing the increasing complexity of the project will become a priority. We also envision that improved algorithms will enter the project as the nature of the couplings of the new integration phenomena becomes clearer. For example, some new algorithms may achieve greater efficiency by combining individual components rather than by treating each component as a block in a high-level algorithmic diagram.

### **10-15 years**

During the final five-year period, the focus will be on comprehensive integration. There will be a link between all the physics components of the project. The mathematical framework will largely be in place for the integration.

Part of the challenge of this final integration will be to include multiple levels of description of the same phenomena. For example, there would be an option for plasma equilibrium to be computed either in the 2D axisymmetric approximation or fully in 3D, including the effects of small magnetic islands. Plasma rotation could be included in either of these calculations or neglected. Each level represents a tradeoff between computational efficiency and physical fidelity.

As the integration proceeds into this final phase, we expect the simulation capabilities to be exercised more, and to have new and more comprehensive comparisons between the simulation and experiment. In many cases this will lead to a validation of the model, but we expect that in some cases it will serve to identify shortcomings or inadequacies of the model that will be subsequently addressed. This final integration will succeed only if all the fundamental components have been adequately addressed and if the component integration is carried out correctly.

We expect that the Fusion Plasma Simulator produced by this fifteen year project will be a living software system that will continue to grow and be modified many years into the future. It will serve an invaluable role as an intellectual integrator of many experimental results and approaches, and will be heavily relied upon to reach decisions regarding the development path of fusion energy.

### ***b. THE FSP AND OTHER OFFICE OF SCIENCE ACTIVITIES***

---

We have stressed throughout this report that the FSP will reach across disciplinary boundaries in order to bring together all relevant expertise required to develop an integrated simulation capability for magnetic fusion systems. This expertise is resident in several units within the DOE Office of Science. Primary among these are the activities within the Office of Fusion Energy Sciences and the Office of Advanced Scientific Computing. Other activities are and will continue to be directly relevant to the success of the FSP. Within the DOE, these include the recently developed SciDAC initiative and materials sciences research within the Office of Basic Energy Sciences.

The SciDAC (Scientific Discovery through Advanced Computation) is one of the new, and critical strategic programs within the Office of Science. One of the SciDAC program's principal goals has been to assemble interdisciplinary teams and laboratories to develop the necessary state-of-the-art mathematical algorithms and software, supported by appropriate hardware and middleware infrastructure, to use terascale computers effectively to advance fundamental research in science that is central to the DOE mission. Substantial success has been achieved towards this goal. The SciDAC success provides an argument for the timeliness of the FSP. Perhaps no area of science is more central to the SciDAC mission than fusion, and five projects were launched under SciDAC auspices in FY 2001 to develop and improve the physics models needed for integrated simulations of plasma systems to advance fusion energy sciences.

One of these projects, the Center for Extended Magnetohydrodynamic Modeling (CEMM), has been able to speed up an Extended MHD modeling code through synergistic interactions with applied mathematicians on another SciDAC team (Terascale Optimal PDE Simulations). The resulting algorithmic improvements have already decreased running times by a factor of two, and further exploitation of certain matrix structures will yield even more improvement.

Another SciDAC fusion project coordinates a multi-institution program on 'Numerical Computation of Wave-Plasma Interactions in Multi-Dimensional Systems.' An applied mathematician on this team was able to recognize and exploit Kronecker product structure in some of the equations underlying simulations within this project. The introduction of this and other such insights into the fusion sciences context has led to codes that are now running two to ten times as fast as previous versions. More detailed physics can now be introduced earlier in the modeling and simulation process, thereby greatly accelerating the pace and scope of the science that can be explored.

A third SciDAC has given rise to the U.S. Fusion Grid (<http://www.fusiongrid.org>), which is now being tested on DIII-D and C-Mod scientific data analysis. Developed under the auspices of the National Fusion Collaboratory SciDAC project, the Fusion Grid presently combines experimental data that is stored on servers at MIT, GA, and PPPL with a computational code located at PPPL to provide greatly improved data analysis throughput rates combined with instant access to the latest versions of a PPPL numerical code. The Fusion Grid is thus beginning to provide a collaborative fusion research environment that is transcending geography.



These and other SciDAC projects, even though currently funded at only a modest level, can be thought of as part of a pilot program. As such, SciDAC will ultimately have succeeded best if it spawns major application-specific initiatives precisely like the one being proposed in this document. Early SciDAC success stories provide compelling proof-of-concept evidence to strongly suggest that appropriately funded interdisciplinary teams, focused on a full-scale integrated program, will successfully deliver a greatly enhanced simulation capability to fusion energy sciences. Such a capability is absolutely essential for realizing our nation's goal of commercially viable fusion power in a realistic timeframe.

Further, there are significant needs in materials modeling of fusion device hardware which must be met to provide a complete FSP predictive capability. This is work that would be carried out in collaboration with the Office of Basic Energy Sciences (OBES). It would range from basic theory of fundamental material processes on the atomic, mesoscopic and continuum levels to the simulation of complex surface and bulk phenomena. Surface processes of interest include sputtering and other erosion mechanisms, implantation, re-deposition and co-deposition of tritium and surface restructuring, and roughening among many surface problems of interest. Bulk processes including crystal lattice displacement damage, the creation of atomic and cluster defects, microstructure evolution, dimensional instabilities, and a variety of embrittlement processes, will also need attention. It is significant that the basic approach to multi-scale modeling of materials, e.g. the passage from atomistic simulations to mesoscopic simulations to continuum simulations, is consistent with and complementary to the multi-scale, multi-year paradigms for the FSP. It would be beneficial for a mutual working relationship to develop between the FSP and OBES to complement those between OFES and OASCR.

We anticipate that the relationship between the FSP and other Office of Science activities will continue to evolve and mature during the life of the FSP. Experience has shown that many advances in basic science have been achieved in the pursuit of goal driven activities such as the FSP. We strongly believe that this pattern will emerge again in the context of this project, thus benefiting both the goals of enhanced energy production and the advancement of fundamental science.

### ***c. ROADMAP IMPLEMENTATION: PROJECT GOVERNANCE & MANAGEMENT***

The FSP initiative will be focused, highly interdisciplinary, and will involve a significant number of people. For these reasons it is extremely important that careful attention be given to governance of the project. The governance structure needs to effectively balance the professional requirements of the creative and individualistic people who will carry out the work with the programmatic needs for focus and timely delivery of results. In addition the structure has to work effectively with the two DOE programs offices, OASCR and OFES, that will support and manage the initiative.

There will be two elements of guidance and oversight needed to reach the technically complex goals indicated in the roadmap, Fig. IV-1, on any of the indicated time scales. The first element, project governance, is the process of coming to the best possible technical judgments when evaluating options to reach project goals. This would include agreements about software architectures, selections of emphasis for physics fundamentals, the down selection of FIIs, and a multitude of other issues of this sort. In addition, there are issues of project management: actual implementation of the broad technical decisions across the FSP, e.g. software standards, tracking of progress, issues of accountability, organization of project reviews, assisting in the representation of the project, and etc.

In the case where several institutions or groups have co-equal technical shareholding status in the FSP, e.g. if the 3-5 multi-institutional FIIs are enfranchised as recommended in this report, the above-drawn distinction has important functional implications. For this circumstance, a sketch of a proposed governance structure is provided below. An analogous set of issues has been addressed by the Community Climate Systems Model (CCSM) activity; see <http://www.cesm.ucar.edu>. While there are significant differences between the nature of the science involved in the CCSM and the initiative discussed here, there nonetheless are sufficient similarities that the CCSM activity can help suggest an optimal structure. The organizational chart suggested is:

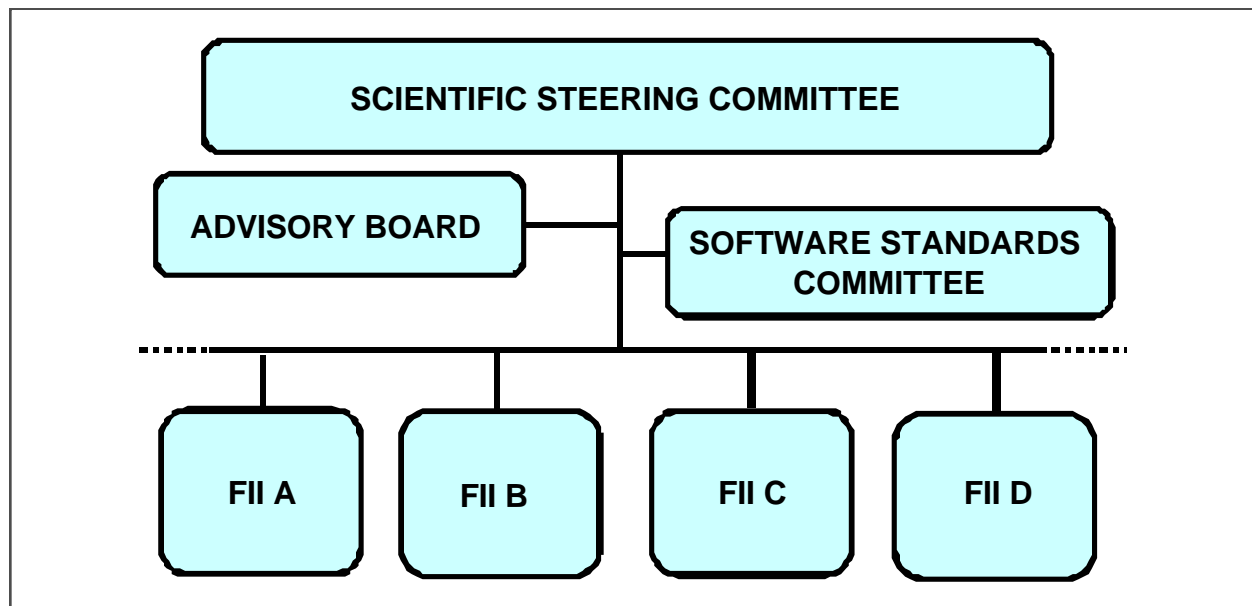

**FigureIV.2.** *Organizational Chart for the Fusion Simulation Project.*

The functions of these organizational groups are:

**Scientific Steering Group (SSG):** This group provides the overall scientific direction and vision for the project. It provides oversight and coordination of scientific activities. It is the key group for assuring that integration is effected. A primary function of this group is outreach at the technical level. The SSG ensures the verification and validation function of the FSP. The SSG will also need to work closely with the program management on the topic of resource allocation issues.

**Advisory Board:** This group is made up of people with scientific breadth that are not directly engaged in the FSP. The group will provide scientific and management advice to both the SSG and program management. A fundamental role of the Advisory Board is to address resource adequacy and FSP collaboration throughout the Office of Science.

**Software Standards Committee (SSC):** This committee is comprised of representatives from each of the FIIs. It is critical that some level of standards and common practice be made across the FSP with respect to software and collaborative tools. The SSC will work to assure the maximum realistic uniformity in software choices throughout the project. The SSC ensures that each FII has a plan for tracking and using software utilities and components developed by other FIIs.

***Focused Integration Initiatives (FIIs):*** Each FII will have the responsibility of carrying out the overarching research plan to which it is committed. Each FII group oversees the scientific direction for its integrated simulation, including determination of required fundamental research, and coupling with experiment. This is where the real work gets done, in fusion science, computational science, and in the cross-disciplinary activities that involve verification and validation.

## V. SUMMARY

---

**T**he goal of the Fusion Simulation Project (FSP) is to develop the computational capacity to perform integrated simulations of toroidal magnetic confinement devices and provide a validated predictive capability. The panel envisions a program proceeding through three five-year phases, the first of which is detailed in this report and would be comprised of focused integration initiatives (FIIs). This development will be made feasible by close coupling of the integration initiative research with ongoing core program activities in theory, experiment, computer science and applied math carried out under the auspices of DOE OFES and OASCR. Our vision for the initiative is detailed in Section III of this report, with the path discussed in Section IV, and a fifteen-year overview roadmap delineated in Fig. IV.1.

Numerical modeling has played a vital role in magnetic fusion for most of its history, with increases in the scope and reliability of simulation enabled by advances in hardware and numerics and through improvements in basic theory. Knowledge gained by this approach has covered the entire range of problems in the fusion energy sciences. A summary of the current state of fusion plasma simulation can be found in the Appendix, where theoretical issues are also surveyed. Some progress in integrated modeling has been made as well, leading to important insights on topics as diverse as major disruptions, turbulence regulation by flows, and the design of compact stellarators.

Achieving the goals of the FSP will require significant collaborative advances in physics, applied mathematics and computer science. The wide range of temporal and spatial scales, extreme anisotropies and complex geometry, make this problem among the most challenging in computational physics. The numerical challenges for fusion simulation are outlined in Sections II*d* and III*e*. Methods for simulating phenomena coupled over disparate space and time scales, and over different dimensionality will require qualitative improvements, innovations and strong collaborations across all of the constituent disciplines. This disciplinary integration will be an essential element of the project. The project must develop software methodologies and frameworks for designing, building, maintaining, and validating the simulation software. Computer science issues raised by this initiative include: the choice of an architecture for interconnecting code modules; data models; performance monitoring and optimization; provision for flexibility and extensibility; and, tools for enabling human collaborations over long distances. These and related topics are also discussed in section III*e*.

Assessment of predictive models has been divided into two distinct activities: verification, which assesses the degree to which a code correctly implements the chosen physical model, and validation, which assesses the degree to which a code describes the real world. Overall, the goal of verification and validation is an assessment of the extent to which a simulation represents true system behavior sufficiently to be useful. Verification is particularly difficult for integrated models where analytic solutions may not be available in any regime. The validation process puts a premium on close collaboration between computational and experimental groups. To succeed, a central feature of this initiative must be an intensive and continual close coupling between the simulations efforts and experiments. The requirements for verification and validation are summarized in section III*f*.

The Fusion Simulation Project will require significant improvements in computational infrastructure. These include advances at major computational facilities which are shared across the Office of Science community as well as deployment and enhancements to local or topical computing centers. The simulations envisioned here will also produce truly prodigious quantities of data and will require

investments in advanced storage systems at all levels. With geographically dispersed resources and researchers, the wide-area network becomes a crucial element in the computing environment, with associated collaborative tools and protocols. Timely upgrades to the communication network and local infrastructure will be required. Of particular concern is connectivity to university or international partners. Infrastructure requirements are detailed in Section IIIg

New funding necessary for the success of the FSP is presently estimated at approximately \$20M per year for each of five years. To achieve the greatest productivity, this new research should be split between OFES and OASCR, with fusion scientists funded by OFES, and applied mathematicians, computer scientists, and the computational toolkits provided under the auspices of OASCR. This joint undertaking represents a significant opportunity for the DOE Office of Science to create a capability that will advance the understanding of fusion energy to a level unparalleled worldwide.

## **VI. ACKNOWLEDGEMENTS**

---

**W**e acknowledge helpful contributions to this report from members of the fusion and applied mathematics communities, with particular thanks to speakers at the May 23 ISOFS workshop, and to the speakers and participants of the September 17-18 FSP workshop. We thank the support staff without whom this activity would not have been possible, including Lucille Kilmer, Deanne Eggers, Ron Winther, Beulah Koz, and Marcia Freels. We also thank the Theory Coordinating Committee (TCC) for their letter, and the members of the PSACI PAC for the concepts and suggestions provided in their 18 June 2002 letter to this Subcommittee, and most particularly appreciate their enthusiasm for the Fusion Simulation Project. We are grateful for the excellent and substantive technical contributions: in the computational science sections of this report, by David Brown and David Keyes; and, in the fusion sections, by Jeff Candy, Ron Cohen, Nasr Ghoniem, Greg Hammett, Wayne Houlberg, David Humphreys, William Nevins, Ron Stambaugh, and Ron Waltz.



**Attachment: ISOFS Charge Letter**

February 22, 2002

Professor Richard D. Hazeltine, Chair  
Fusion Energy Sciences Advisory Committee  
Institute for Fusion Studies  
University of Texas at Austin  
Austin, TX 78712

Dear Professor Hazeltine:

This letter provides a charge to the Fusion Energy Sciences Advisory Committee (FESAC) to assist the Office of Fusion Energy Sciences (OFES) in preparing a roadmap for a joint initiative with the Office of Advanced Scientific Computing Research (OASCR). Recent reports, such as the FESAC report "Priorities and Balance within the Fusion Energy Sciences Program," the "Report of the Integrated Program Planning Activity" (IPPA), and the NRC report "An Assessment of the Department of Energy's Fusion Energy Sciences Program," have identified a predictive understanding as a measure of the quality of the science and the maturity of the knowledge base of a field. The IPPA report lists several challenging 10-year objectives for the fusion program, including "develop fully integrated capability for predicting the performance of externally-controlled systems including turbulent transport, macroscopic stability, wave-particle physics, and multi-phase interfaces." This objective, as well as several other IPPA objectives related to innovative confinement configurations, will require significantly enhanced simulation and modeling capability. Therefore, the goal of this initiative should be to develop an improved capacity for **Integrated Simulation and Optimization of Fusion Systems**.

The initiative should be planned as a 5-6 year program, which would build on the improved computational models of fundamental processes in plasmas that are being developed in the base theory program and in the SciDAC program. Rough estimates are that an integrated simulation initiative would require a total funding level of about \$20 million per year, with funding for the plasma scientists provided by OFES and funding for the applied mathematicians, computer scientists, and computational resources provided by OASCR. Thus, the roadmap should include not only human resources but also computer and network resources.

Please carry out the preparation of the roadmap using experts outside of FESAC membership, as necessary, including experts recommended by the Advanced Scientific Computing Advisory Committee. The sub-panel of experts should obtain community input through a series of workshops covering at least the following questions:

- What is the current status of integrated computational modeling and simulation?
- What should be the vision for integrated simulation of toroidal confinement fusion systems?

- What new theory and applied mathematics are required for simulation and optimization of fusion systems?
- What computer science is required for simulation and optimization of fusion systems?
- What are the computational infrastructure needs for integrated simulation of fusion systems?
- How should integrated simulation codes be validated, and how can they best be used to enable new scientific insights?

The ultimate product should be a roadmap document similar to the one developed for the Genomes to Life Initiative (<http://www.doegenomestolife.org/roadmap/index.html>). Please conduct a workshop on the first two questions above and provide a summary document with overall program goals and objectives, major program deliverables, and a brief description of the OFES and OASCR funded elements of the program by July 15, 2002, so that OFES would be able to include a description of the program in the FY 2004 OMB budget request. Please complete work on the final roadmap by December 1, 2002, in order to provide the detailed information needed by OFES and OASCR to develop detailed program plans, program announcements and grant solicitations.

I appreciate the time and energy that members of FESAC and FESAC sub-panels have provided to the continuing efforts to develop program plans and roadmaps for the OFES program. I am confident that the Committee's recommendations on a roadmap for **Integrated Simulation and Optimization of Fusion Systems** will form a sound basis for beginning a joint OFES/OASCR program.

Sincerely,

James F. Decker  
Acting Director  
Office of Science

# **FRONT COVER ATTRIBUTION LIST**

*(APPEARS ON BACK COVER)*

*B. Carreras, W. Dorland, L. Garcia  
G. Hammett, G. Kerbel, C. Kim  
J-N. Leboeuf, V. Lynch, W. Park  
S. Parker, B. Rogers, C. Sovinec  
D. Spong, R. Sydora, NCSX Team  
W7-X Team*